

Detailing Guide for Heat Pump Penetrations in Existing Buildings

About This Guide

This guide provides detailing methods for heat pump penetrations through walls in existing buildings. The penetrations include typical line set, electrical wire, and conduit components.

Correct penetration detailing includes seals and water-shedding components to maintain continuity of the control layers. Incorrect detailing can result in damage to the building enclosure from water and air leakage.

The diagram below shows the control layers in a typical wall assembly. See also the annotated diagram in Detail D-1A on page 5.

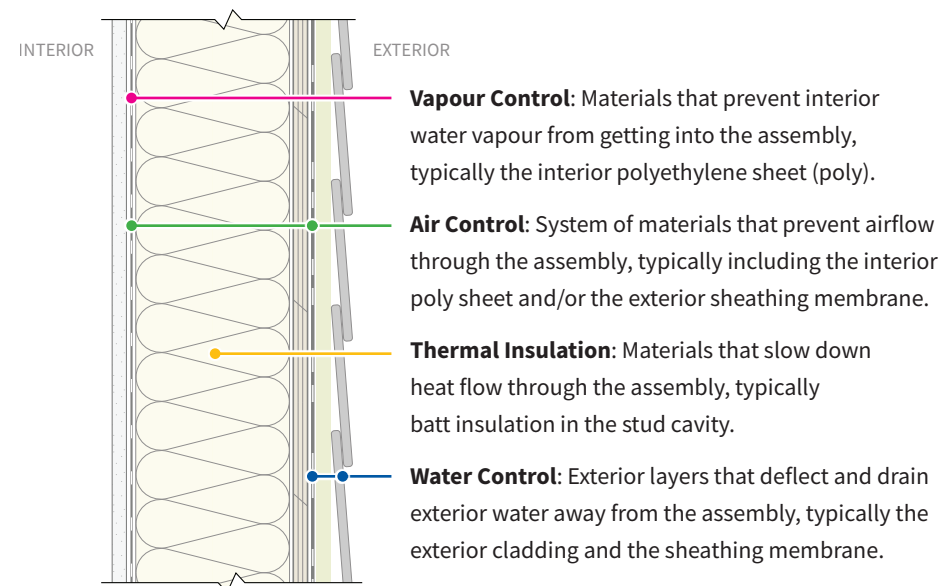

Most details show air control continuity for both the interior poly and the exterior sheathing membrane. This approach provides consistent continuity for air control layer(s) in the existing assembly. Furthermore, most details show a sequence of hole-saw openings for the penetration instead of disassembly of interior finishes and cladding. This retrofit approach can make maintaining water control continuity easier, but requires careful sequencing and sealing work. Refer to the Installation Best Practices on page 3.

Heat Pump Retrofit Checklist

The details in this guide do not provide instructions beyond the penetrations through the existing enclosure. Before completing any heat pump retrofit installation work, ensure the following considerations have been addressed:

- Confirm that the building occupants/owners have permission from their strata corporation and the Authority Having Jurisdiction (AHJ) to complete the work.
- Confirm if the heat pump retrofit requires an electrical permit, mechanical permit, and/or building permit, and involvement from a registered professional.
- Complete an electrical load calculation to ensure there is enough capacity on the existing panel. Upgrade the electrical service/panel if needed.
- Plan the heat pump drain line route for discharging condensate water.
- Confirm that the heat pump outdoor unit location complies with city bylaws or permit requirements for outdoor mechanical equipment, setbacks, and egress routes.
- Locate the heat pump to avoid long line set runs and tight loops.
- Confirm that the products and detailing methods are acceptable to the AHJ when using this detailing guide.
- Ensure that the existing enclosure components are in sound condition and adequately attached to the building before attempting to fasten or seal to them.
- Visit bchousing.org/research-centre/library for more resources and guidance on building enclosure design and detailing.

See the Additional Resources list on page 4 for further guidance on best practices for penetration detailing and heat pump retrofit planning and installation.

Disclaimer

This guide is provided for general information only. Care has been taken to confirm the accuracy of the information contained herein; however, the authors, funders, publisher, and other contributors assume no liability for any damage, injury, loss, or expense that may be incurred or suffered as a result of the use of this publication, including products, building techniques, or practices. The views expressed herein do not necessarily represent those of any individual contributor.

Building products and construction practices change and improve over time, and it is advisable to regularly consult up-to-date technical publications rather than relying solely on this publication. It is also advisable to seek specific information on the use of products, the requirements of good design and construction practices, and the requirements of the applicable building codes before undertaking a construction project. Consult the manufacturer's instructions for construction products, and also speak with and retain consultants with appropriate architectural and/or engineering qualifications, and appropriate municipal and other authorities, regarding issues of design and construction practices. Provisions of British Columbia Building Code (BCBC) and the Vancouver Building By-law (VBBL) have not been specifically referenced, and use of the guide does not guarantee compliance with code requirements, nor does the use of systems not covered by this guide preclude compliance. Always review and comply with the specific requirements of the applicable building codes for each construction project. The materials and colours shown as examples in the guide are not intended to represent any specific brands or products, and it is acknowledged that many product options exist.

This guide typically shows the least intrusive detailing methods that can still achieve adequate continuity in low and moderate exposure conditions. For high exposure conditions, more comprehensive detailing work is required as shown in the details which are labelled accordingly.

Making changes to any enclosure assembly on a building that falls outside Part 9 of the BCBC/VBBL (i.e., it is greater than three storeys or more than 600 m² total floor area) requires oversight from a registered professional (i.e., Architect or Professional Engineer).

The fire protection requirements and considerations for new service penetrations in existing assemblies have not been specifically referenced in this guide. Consult with your building official and a qualified fire protection consultant before making any changes to your building.



Funded with assistance from

Detailing Considerations

Penetrations in Low Exposure Areas

Locating holes in wall areas that are away from regular direct water exposure to reduce the risk of unintended water leakage at the service penetration. Long-term direct rain and snow exposure can quickly degrade the penetration detailing and lead to damage of the wall assembly. Where possible, locate penetrations under overhangs or waterproof balconies, in alcoves and inset wall areas, and under existing wall flashing. If the wall area has obvious signs of discoloration from weathering or regular wetting patterns, it may not be appropriate to add a large penetration through it. When in doubt, use detailing for high exposure conditions as indicated in this guide.

Exposure Risk Assessment With the Exposure Nomograph

The exposure risk can be broadly categorized as either low exposure or high exposure. The typical penetration details shown are intended for low exposure conditions since they do not typically include direct lapping into the existing water control layers or the use of dedicated deflection flashing. Use the following exposure nomograph to assess the exposure risk for a given wall area. See the Additional Resources list on page 4 for further guidance on assessing the exposure risk.

- 1 Calculate the Overhang Ratio for the penetration location on the wall (see below).
- 2 Choose the terrain category that best describes the building location.
- 3 Determine the Moisture Index (MI) for your location. The MI values for municipal locations are listed in Appendix C, Division B of the BCBC.
- 4 Draw a line between the exposure ratio and the terrain.
- 5 Identify the exposure risk based on where the line crosses the Moisture Index bar.

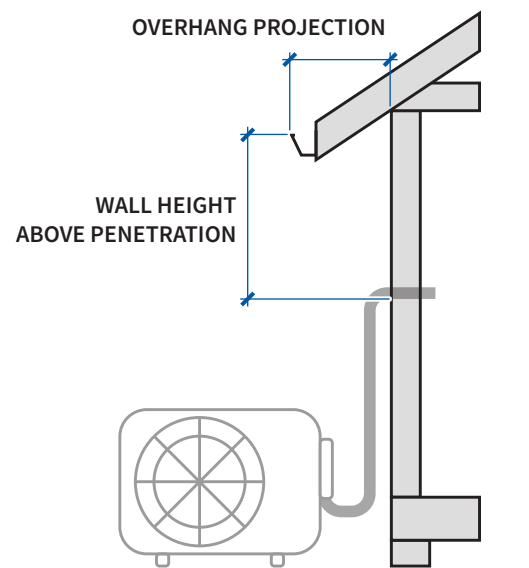

$$\text{OVERHANG RATIO} = \frac{\text{OVERHANG PROJECTION}}{\text{WALL HEIGHT ABOVE PENETRATION}}$$

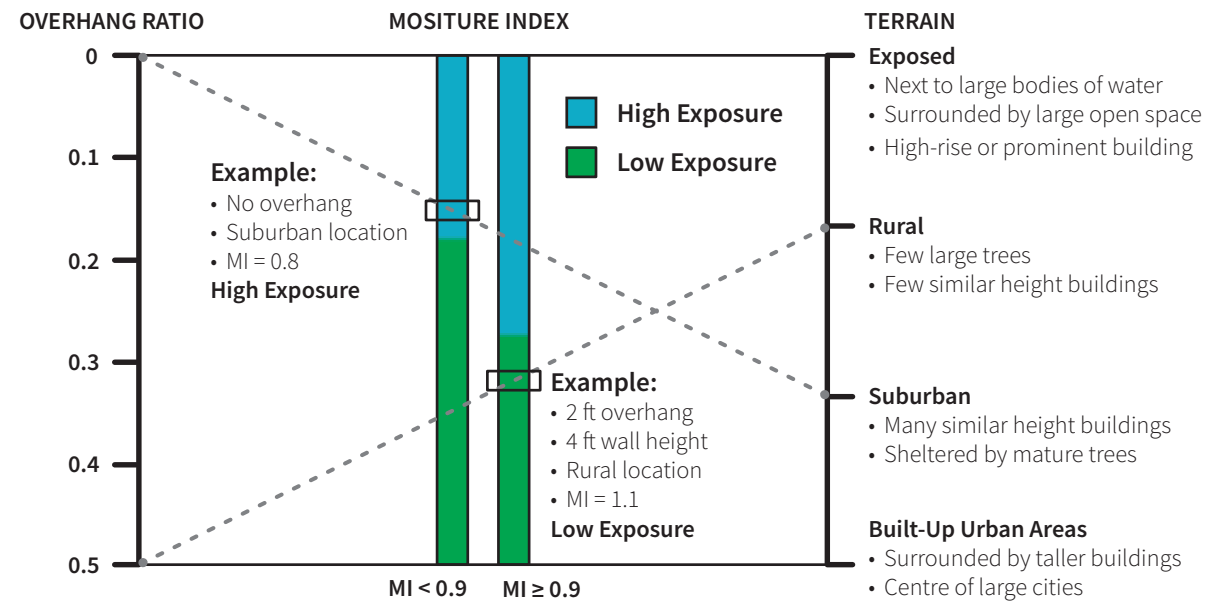

Other Heat Pump Outdoor Location Constraints

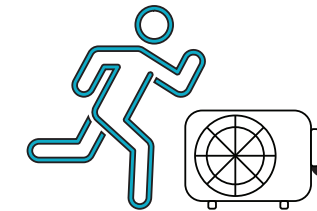

Locate away from egress routes

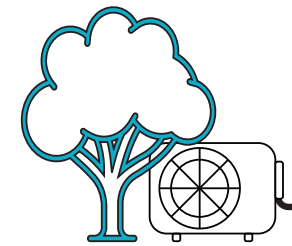

Avoid airflow obstructions

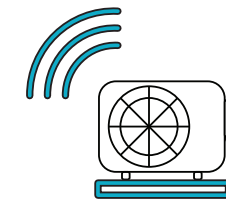

Reduce noise and vibrations

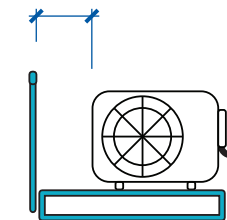

Do not create falling hazards

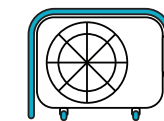

Prevent tipping hazards

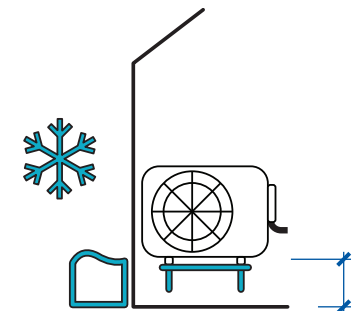

Elevate above snow

Detailing Considerations

Appropriate Materials and Components

The details in this guide show materials and components that can simplify the installation process while ensuring continuity of the building enclosure control layers. Always confirm products and methods are acceptable to the Authority Having Jurisdiction (AHJ).

- › Commercial-grade construction sealant formulated for "low energy surface" materials should be used on synthetic smooth surfaces that can otherwise be hard to adhere to. This is usually a silicone-based product, specifically labelled as such. Consumer-grade sealant is typically not appropriate.
- › Hard foam plastic backer rod helps keep the components in position when sealant is applied. Soft backer rod can deform and make it difficult to create a continuous seal.
- › Adhesive line set tape is used to provide control layer continuity around the bundled line set. Use high-tack adhesive tape for wrapping the line set into a bundle. This includes conventional sheathing tape, "high-performance adhesive tape", and "stucco tape". Conventional woven line set wrap is not appropriate as a control layer transfer tape.
- › Putty sealant is typically sold as "electrical putty", "duct putty", or "firestop putty". It usually comes as small bricks or pads.
- › Unreinforced 60-mil EPDM roofing membrane is a flexible rubber material that can be sourced as individual patches or cut from full-size roofing membrane rolls. It should be cut using a sharp utility knife to avoid nicks.
- › High-performance detailing tape is used to adhere and seal around EPDM. It is typically sold as "high-performance adhesive tape" specifically made for building detailing applications and often uses an acrylic-based adhesive.
- › Solid schedule 20 PVC pipe, often termed "sewer pipe", is well-suited as line set conduit because it has thinner walls compared to schedule 40 pipe. Adjustable or multi-piece sleeve inserts that are not reliably air- and water-tight are not appropriate.
- › Flanged duct collars can be sourced from HVAC suppliers and online general supply stores. They should be sized to fit inside the conduit pipe and span out over the hole saw opening in the wall.
- › Firestopping accessories and sealant have not been specifically identified. Confirm with your Building Official and fire consultant before employing firestopping materials.

Installation Best Practices

The detailing approaches shown require careful application. Detailing to ensure continuity of the enclosure control layers requires skill and experience.

- 1 Position the penetrations and outdoor unit so that the line set can be turned downward as it comes out to prevent water from tacking back to the opening.
- 2 Use hole saw guide plates and appropriate power drill tools to achieve clean, consistent hole saw openings.
- 3 Slowly cut into rainscreen cladding to avoid damage to the sheathing membrane. Use an oscillating tool and a metal backing plate slipped behind the strapping when cutting against the sheathing membrane.
- 4 Clean all surfaces before applying sealant, tape, or the EPDM gasket.
- 5 Apply sealant with a nozzle that has been cut to size to match the bead or opening size and use an adjustable or elbow nozzle where needed.
- 6 Tool the sealant beads to ensure continuous contact and a consistent profile.
- 7 Roll the sealant putty into cylinders so it is malleable and wrap it around each line before compressing it all together and wrapping it with tape.
- 8 Press the line set tape into place over all the areas to create a continuous, well-adhered wrap around the line set.
- 9 Test fit the EPDM gasket before installing it. There should be a snug fit but without over-stretching the material around the component.
- 10 Bend and position the line set roughly before applying sealant. Avoid moving components excessively after the sealant has been installed.
- 11 Do not use spray foam to try to create a seal or for insulation.
- 12 Install deflection flashing and trim board to create a continuous water deflection surface over the cladding opening for high exposure areas.
- 13 Prioritize good quality control by documenting with photos and mid-point inspections where needed before the detailing gets covered up. Consider making a separate mock-up to practice the retrofit steps.
- 14 Remember that the penetration components may need to be removed for servicing and repair. Avoid excessive or messy sealant and consider leaving a record of the detailing approach used with the homeowner for their records.
- 15 Adapt the detailing for unique wall areas and penetrations through the rim joist but keep the same sealing approach from the exterior where possible.

Firestopping for Openings in Fire-Rated Assemblies

The exterior walls of a building may require a fire resistance rating on the interior side due to proximity to property lines or adjacent buildings. This protection rating is applied to the wall area, with an allowance for openings that are unprotected. The permitted percentage of unprotected openings like doors, windows, and service penetrations through the wall is determined through the spatial separation requirements of the applicable building code. Fire protection of additional wall penetrations may be required if the permitted percentage of unprotected openings is maximized by the existing unprotected openings. The firestopping requirements of the applicable building codes address the protection of these additional penetrations (i.e., typically Subsection 3.1.9. of the BCBC).

The specific configuration and components for this detailing can vary widely based on the type of penetration, the firestopping requirements, and the products used. This guide includes one example detail with generic interior line set firestopping based on currently available products. It does not specify installation procedures or required components. Firestopping sealant is also referenced for each detail and in some cases implied in the graphic. It is not to be relied upon for fire protection detailing or code compliance purposes. Always consult with your Building Official and a qualified fire protection consultant before making any changes to your building.

List of Heat Pump Retrofit Penetration Details

List of Details

D-1A Line Set Through Rainscreen Cladding	5
D-1B Line Set Through Non-Rainscreen Cladding.	6
D-1C Line Set Through EIFS Cladding	7
D-1D Line Set Through Exposed Concrete	8
D-1E Line Set Through Window Wall Spandrel.	9
D-1F Line Set Through Exterior-Insulated or Deep Rainscreen	10
D-1G Line Set Through Rainscreen in High Exposure and/or Firestopping Conditions	11
D-2A Electrical Disconnect Box on Rainscreen Cladding.	12
D-2B Electrical Disconnect Box on Non-Rainscreen Cladding	13
D-2C Electrical Disconnect Box on Rainscreen Cladding in High Exposure Conditions	14
D-3A Conduit/Pipe Through Rainscreen Cladding	15
D-3B Conduit/Pipe Through Non-Rainscreen Cladding	16
D-3C Conduit/Pipe Through Rainscreen Cladding in High Exposure Conditions	17

Additional Resources

- › Vancouver Building By-law (VBBL) 2019 | King's Printer for British Columbia | bccodes.ca
- › British Columbia Building Code (BCBC) 2024 | King's Printer for British Columbia | bccodes.ca
- › Building Envelope Guide for Houses - Part 9 Residential Construction | BC Housing | bchousing.org
- › Building Enclosure Design Guide - Wood-Frame Multi-Unit Residential Buildings | BC Housing | bchousing.org
- › City of Vancouver Heat Pump online resource webpage | vancouver.ca/mechanical-permit
- › City of Vancouver Bulletin - Heat Pumps for Existing Ground-Oriented Dwellings | vancouver.ca/mechanical-permit
- › City of Vancouver Bulletin - Installing a Heat Pump on Balconies and Decks | vancouver.ca/mechanical-permit
- › LEEP Net Zero Energy Wall Guides - Appendix A: Building Material Product Selection Guide | natural-resources.canada.ca

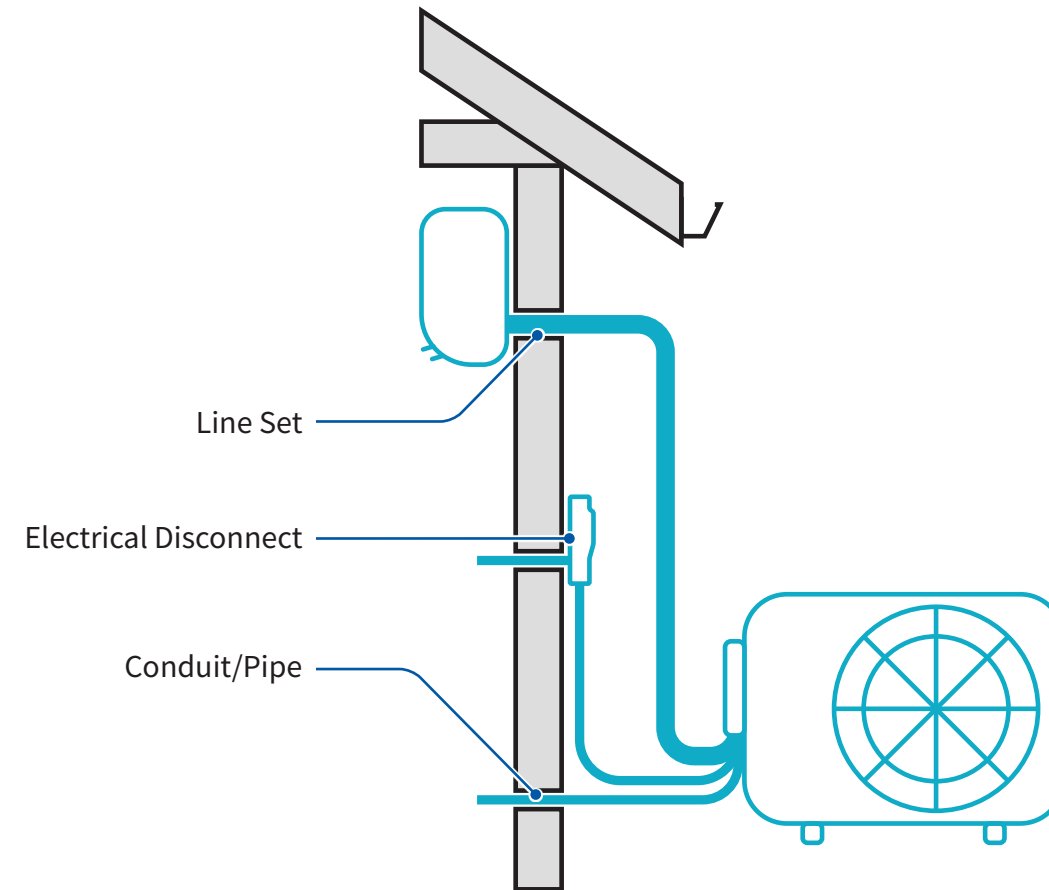

D-1A | Line Set Through Rainscreen Cladding

Materials (for typical line set sizes)

- › 3" PVC conduit (schedule 20), 3" flanged duct collars
- › Construction sealant for low surface energy materials, hard backer-rod
- › Adhesive line set tape, putty sealant, line set cover kit

Steps (refer to Detailing Considerations on page 2)

- 3.25" hole saw opening in the interior finish and poly sheet, with a pilot hole to the exterior with a 2% downward slope.
- 4.25" hole saw opening in the cladding, aligned with the pilot hole, made to avoid damage to the sheathing membrane where possible.
- 3.25" hole saw opening in the sheathing membrane and sheathing (after the 4.25" hole in the cladding).
- Sealant tooled between the interior poly sheet and the interior finish around the perimeter of the hole.
- 3" PVC conduit cut to depth and inserted through the openings.
- 3" duct collar set into sealant around the PVC conduit, interior finish, and at the exterior sheathing membrane, and fastened in place.
- Line set inserted through the PVC conduit, with continuous line set tape over the portions within the conduit, and lines splayed to allow putty installation.
- Hard backer rod baffle/insulation around the line set in the conduit as space and access permits.
- Continuous putty "rings" around each line to make them airtight when ganged together, and line set tape continued over the putty rings to compress them in place.
- Continuous hard backer-rod around the line set in the conduit and a continuous sealant bead tooled around the line set.
- Line set cover receiver set into sealant on the cladding and fastened in place.
- Line set cover clipped/fastened in place as needed.
- Interior hard backer rod and continuous tooled sealant bead around the line set as space and access permits (applies to all line set penetrations).

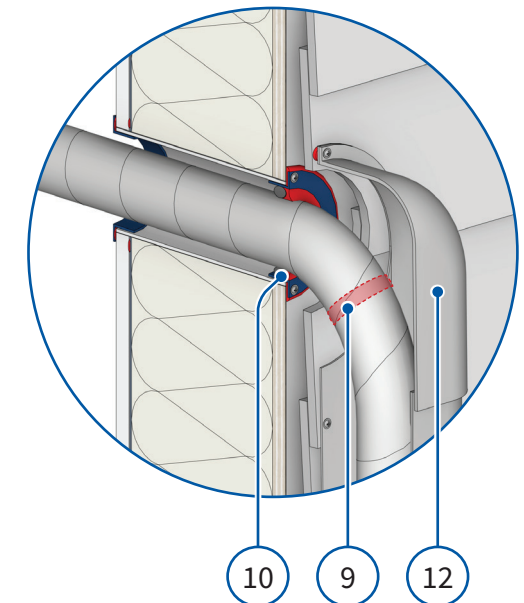
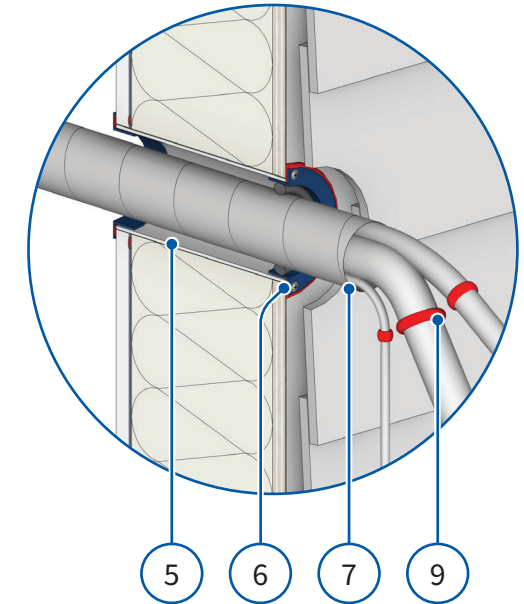
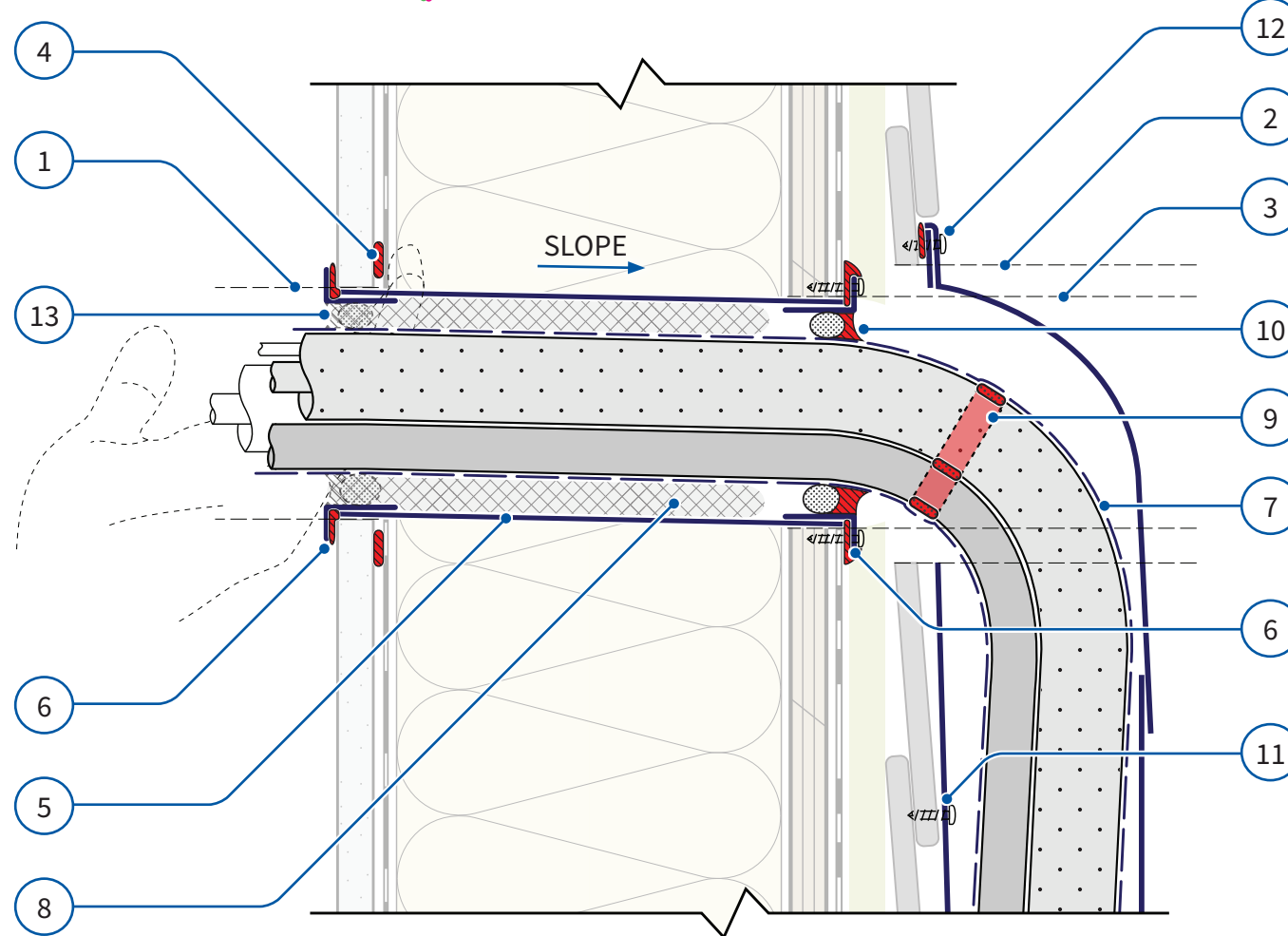
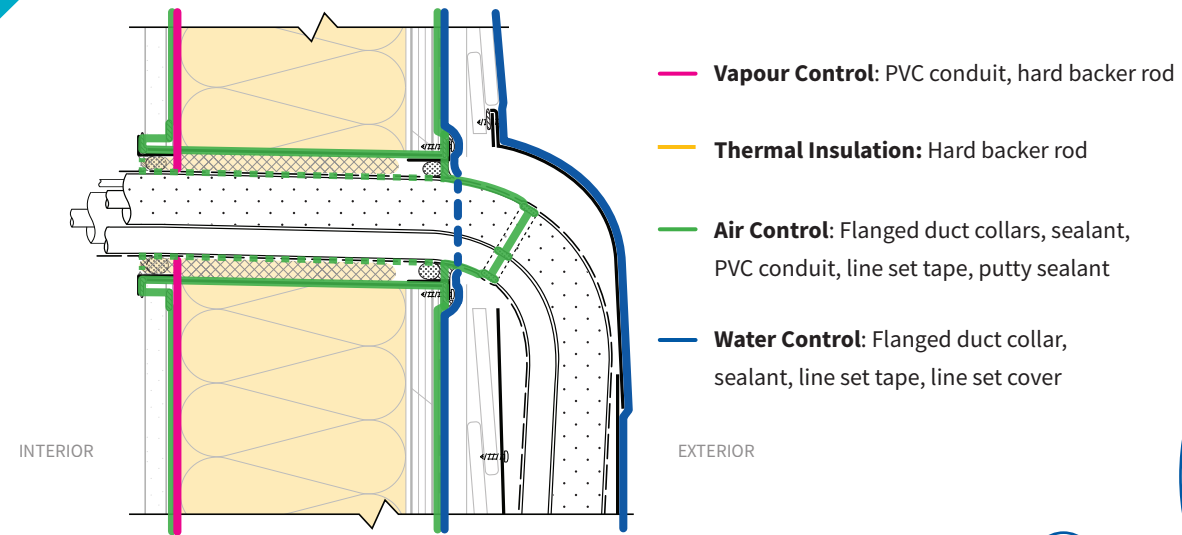

Disclaimer: This assembly configuration and detailing approach are for information purposes only. Consult the product manufacturer's instructions, confirm material compatibility, and speak with and retain consultants with appropriate qualifications. Confirm issues related to design and construction practices with your building official. All dimensions are to be checked against site conditions; drawing is not to be scaled to obtain dimensions. See also the full disclaimer on page 1.

D-1B | Line Set Through Non-Rainscreen Cladding

Materials (for typical line set sizes)

- › 3" PVC conduit (schedule 20), 3" flanged duct collars
- › Construction sealant for low surface energy materials, hard backer-rod
- › Adhesive line set tape, putty sealant, line set cover kit

Steps (refer to Detailing Considerations on page 2)

- 1 3.25" hole saw opening in the interior finish and poly sheet, with a pilot hole to the exterior with a 2% downward slope.
- 2 4.25" hole saw opening in the cladding, aligned with the pilot hole.
- 3 3.25" hole saw opening in the sheathing membrane and sheathing (after the 4.25" hole in the cladding).
- 4 Sealant tooled between the interior poly sheet and the interior finish around the perimeter of the hole.
- 5 3" PVC conduit cut to depth and inserted through the openings.
- 6 Sealant tooled around the cladding opening and between the sheathing, membrane, and cladding. Temporary pry bar or shims used as needed to pull the cladding out for sealant access.
- 7 3" duct collars with flanges set into sealant around the conduit, the interior finish and at the exterior, and fastened in place. Sealant tooled around the exterior duct collar.
- 8 Line set inserted through the PVC conduit, with line set tape only over the portions within the conduit, and lines splayed at the exterior to allow putty installation.
- 9 Hard backer rod baffle/insulation around the line set in the conduit as space and access permits.
- 10 Continuous putty "rings" around each line to make them airtight when ganged together, and line set tape continued over the putty rings to compress them in place.
- 11 Continuous hard backer-rod around the line set in the conduit and a continuous sealant bead tooled around the line set.
- 12 Line set cover receiver set into sealant on the cladding and fastened in place.
- 13 Line set cover clipped/fastened in place as needed.

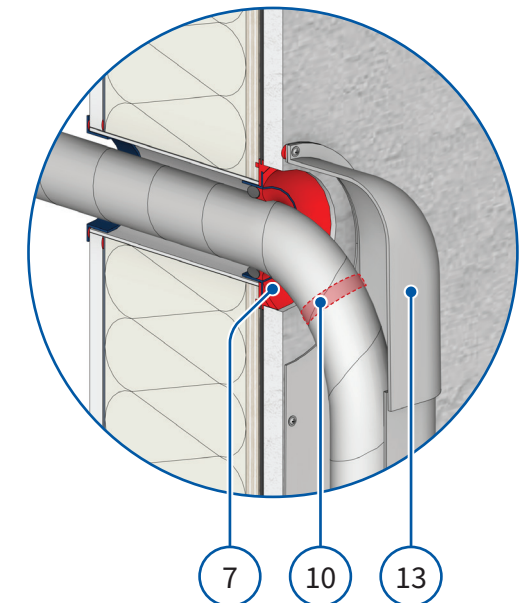
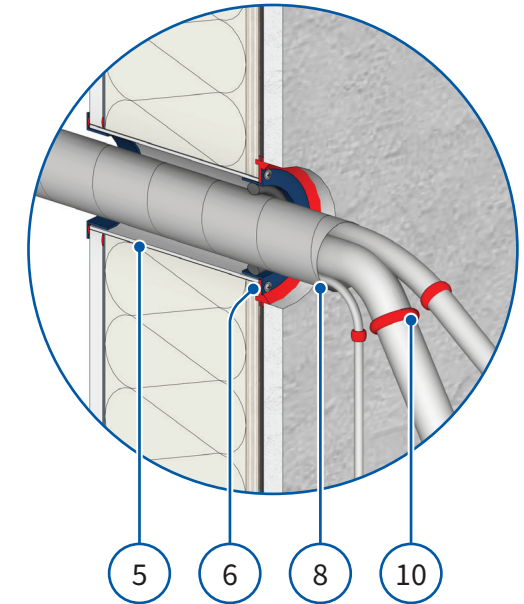
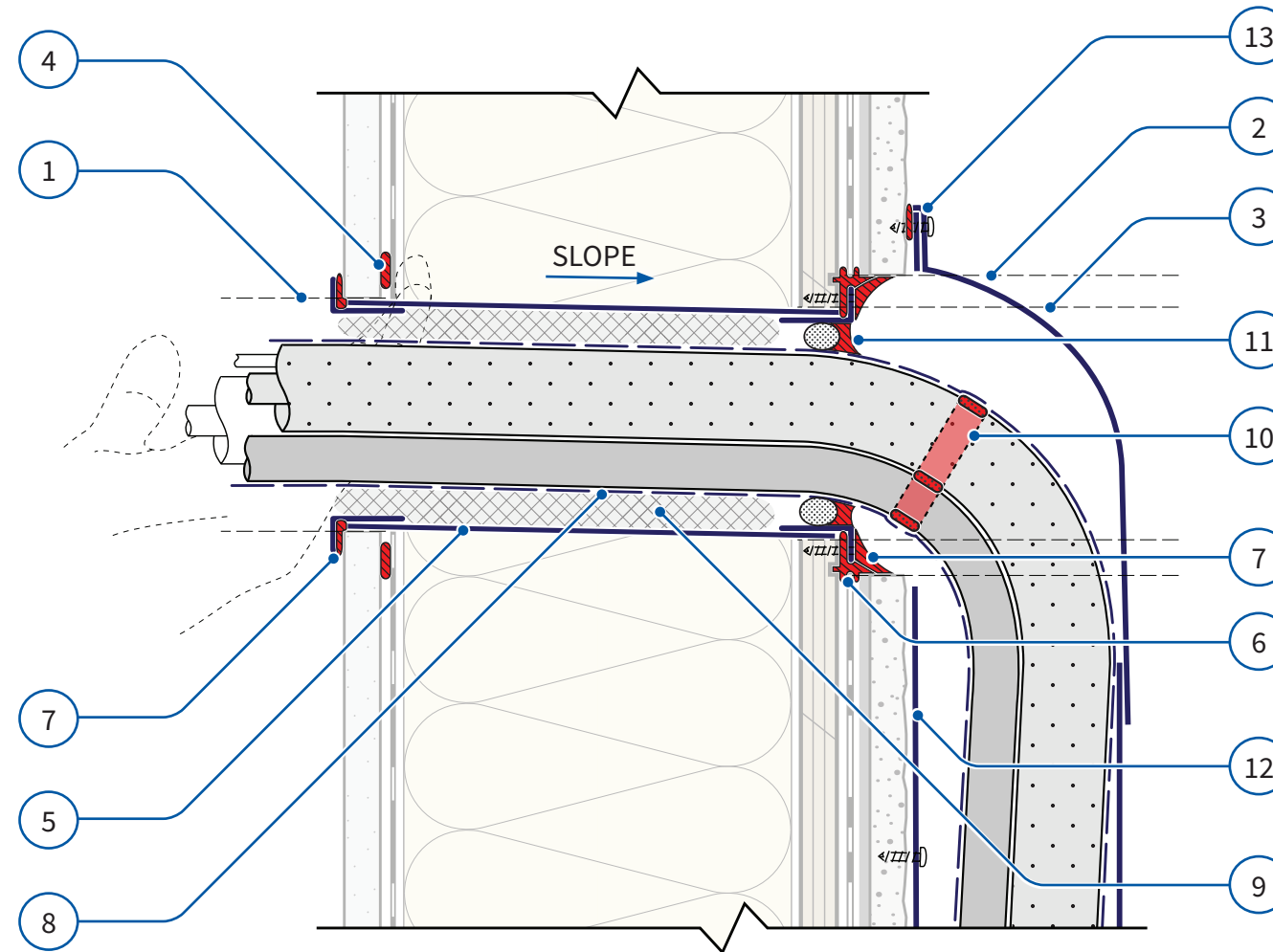

D-1C | Line Set Through EIFS Cladding

Materials (for typical line set sizes)

- › 3" PVC conduit (schedule 20), 3" flanged duct collar
- › Construction sealant for low surface energy materials, hard backer-rod
- › High-performance detailing tape, unreinforced EPDM gasket membrane
- › Compatible EIFS repair mortar with mesh reinforcing, mineral wool insulation block
- › Adhesive line set tape, putty sealant, line set cover flashing

Steps (refer to Detailing Considerations on page 2)

- 1 3.25" hole saw opening in the interior finish and poly sheet and in the EIFS, with 2% downward slope to the exterior.
- 2 Rectangular opening in the EIFS with at least 2.5" clearance around the hole.
- 3 EIFS repair including reinforcing mesh applied over the exposed foam and at least 2" onto the face of the existing wall and EIFS on all sides.
- 4 Sealant tooled between the interior poly sheet and the interior finish around the perimeter of the hole.
- 5 3" PVC conduit cut to depth and inserted through the openings, and an EPDM membrane with an under-sized hole fit around the conduit (see sizing guide).
- 6 EPDM taped at all edges onto the new EIFS patch on the existing wall with high-performance detailing tape. Void infilled with insulation block cut to fit snugly.
- 7 3" duct collar with flanges set into sealant around the conduit and interior finish.
- 8 Line set inserted through the PVC conduit, with line set tape only over the portions within the conduit, and lines splayed at the exterior to allow putty installation.
- 9 Hard backer rod baffle/insulation around the line set in the conduit as space and access permits.
- 10 Continuous putty "rings" around each line to make them airtight when ganged together, and line set tape continued over the putty rings to compress them in place.
- 11 Continuous hard backer-rod around the line set in the conduit and a continuous sealant bead tooled around the line set.
- 12 Replacement insulation block fitted around the line set, fastened in place as needed.
- 13 Line set cover flashing fastened on shims with sealant tooled at the top and sides and over the fasteners.

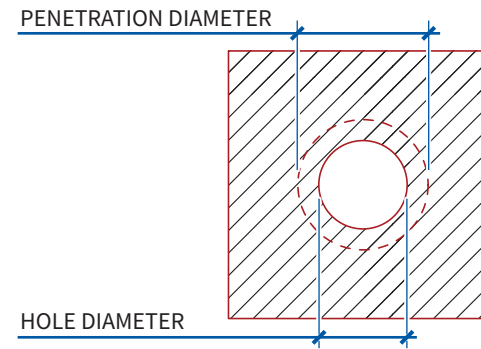

Typical EPDM gasket hole diameter sizing guide

- › Penetrations ≤ 1" - size hole diameter @ approximately 40% of the penetration diameter
- › Penetrations >1" to ≤ 3.5" - size hole diameter @ approximately 60% of the penetration diameter
- › Penetrations > 3.5" - size hole diameter @ 1.5" smaller than the penetration diameter

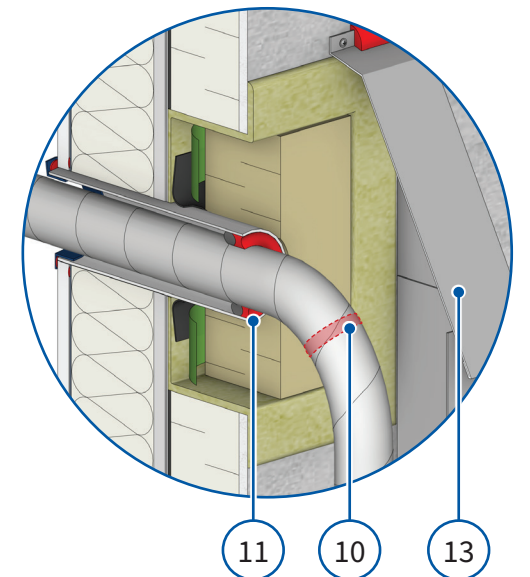
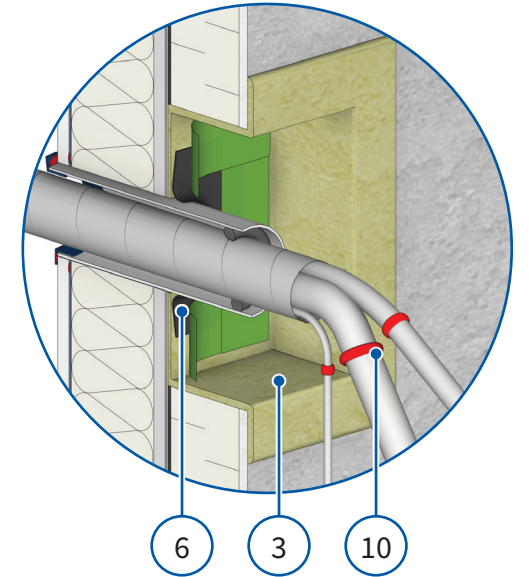
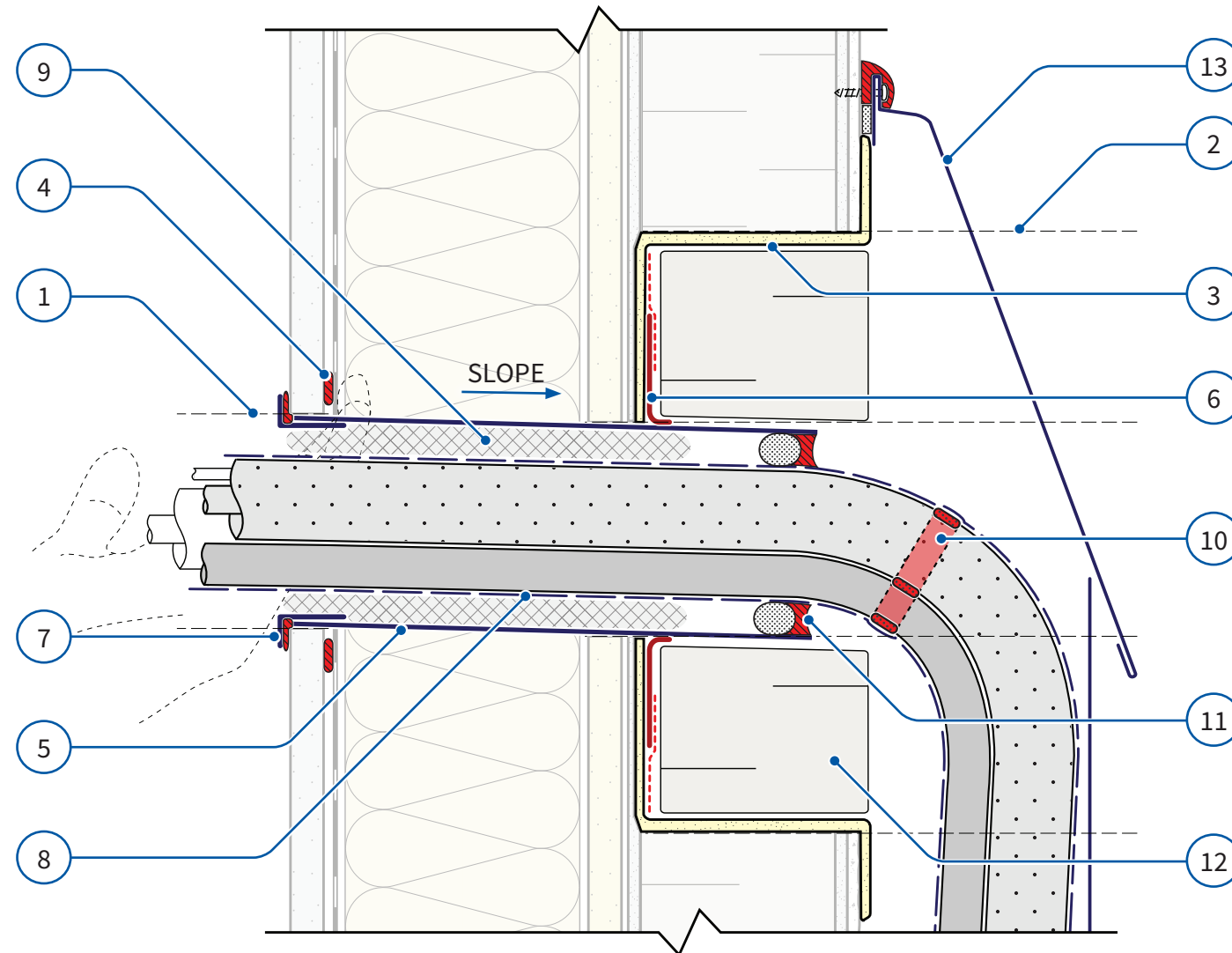

D-1D | Line Set Through Exposed Concrete

Materials (for typical line set sizes)

- › 3" PVC conduit (schedule 20), 3" flanged duct collars
- › Construction sealant for low surface energy materials, hard backer-rod
- › Adhesive line set tape, putty sealant, line set cover flashing

Steps (refer to Detailing Considerations on page 2)

- 1 3.25" hole saw opening in the interior finish and poly sheet, with a pilot hole to the exterior (sloped 2% if possible)
- 2 3.25" cored opening through the concrete, aligned with the pilot hole.
- 3 Sealant tooled between the interior poly sheet and the interior finish around the perimeter of the hole.
- 4 3" PVC conduit inserted through the interior opening and set into a sealant bead around the concrete cored opening.
- 5 3" duct collar with flanges set into sealant around the conduit and interior finish.
- 6 Line set inserted through the opening, with line set tape only over the portions within the conduit/concrete, and lines splayed at the exterior to allow putty installation.
- 7 Hard backer rod baffle/insulation around the line set as space and access permits.
- 8 Continuous putty "rings" around each line to make them airtight when ganged together, and line set tape continued over the putty rings to compress them in place.
- 9 Continuous hard backer-rod around the line set in the concrete opening and a continuous tooled sealant bead around the line set.
- 10 Line set cover flashing fastened on shims and with sealant at the top and sides and over the fasteners.

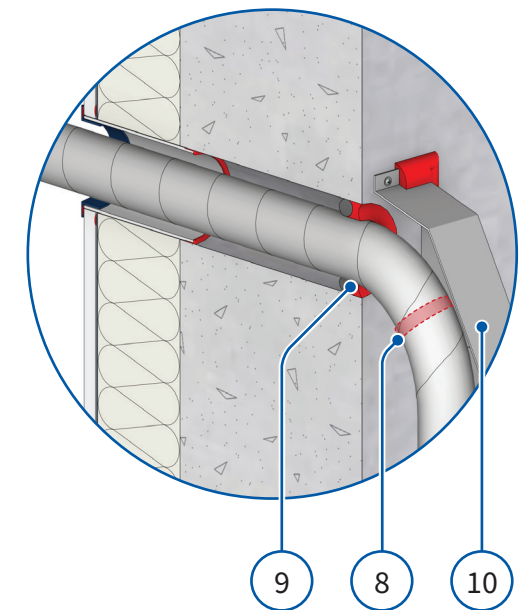
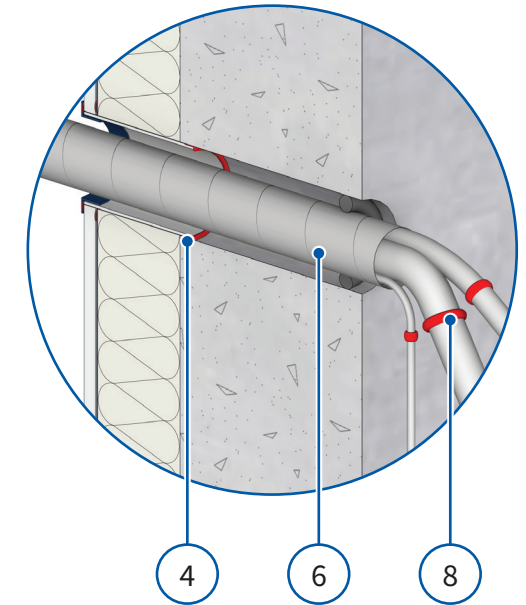
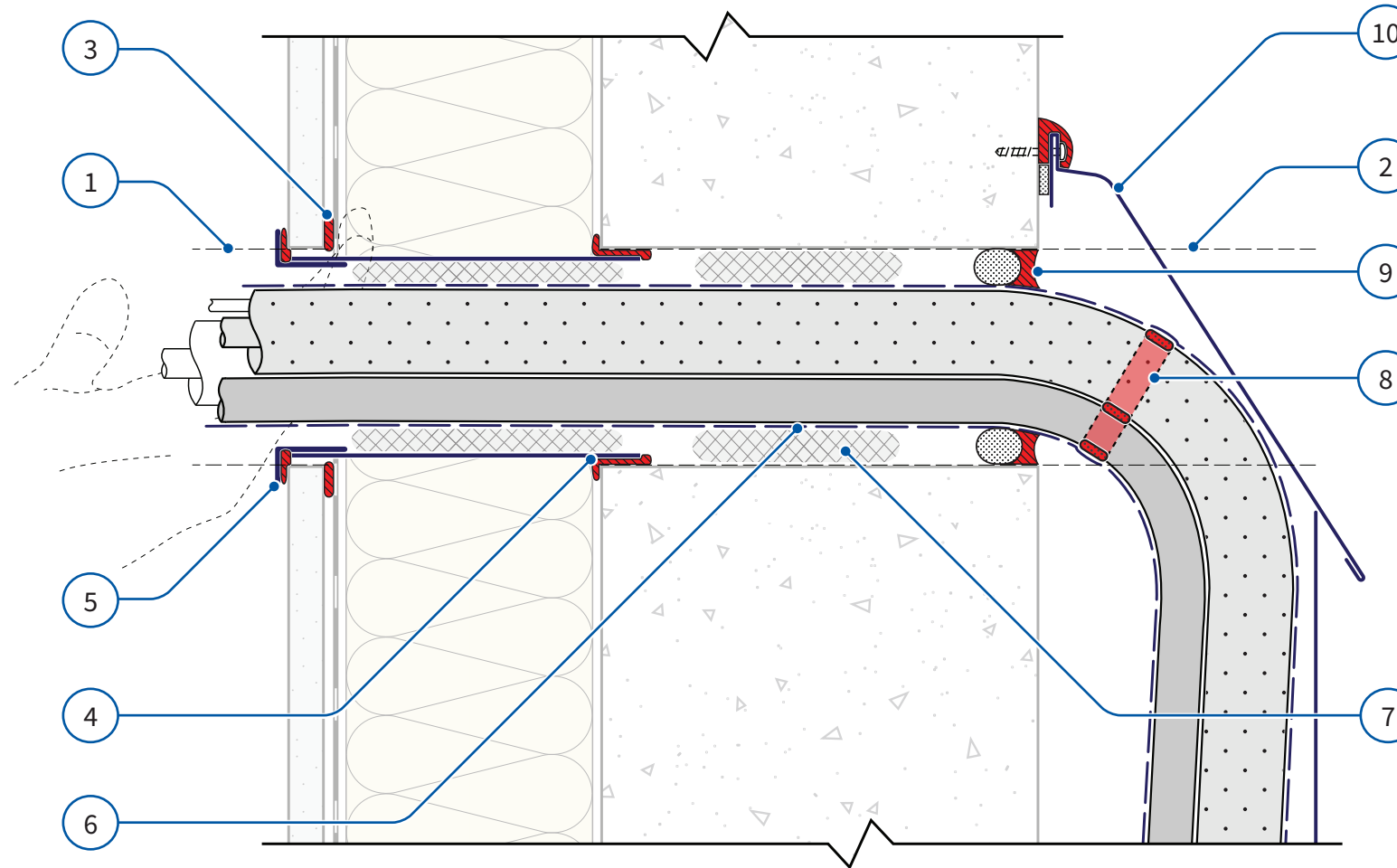

D-1E | Line Set Through Window Wall Spandrel

Materials (for typical line set sizes)

- › 3" flanged duct collars
- › Construction sealant for low surface energy materials, hard backer-rod
- › Adhesive line set tape, putty sealant, line set cover flashing

Steps (refer to Detailing Considerations on page 2)

- 1 3" hole saw opening in the window wall backpan.
- 2 Spandrel insulation cored out to the diameter of the line set.
- 3 3" hole saw opening in the window wall spandrel panel. If spandrel glass is used instead, replace it with an appropriate panel that can receive a hole saw opening, such as a metal sandwich panel.
- 4 Duct collars with flanges set into sealant at the interior of the backpan and at the exterior of the spandrel panel, and fastened in place as needed.
- 5 Line set inserted through the duct collars, with line set tape only over the portions within the spandrel space, and lines splayed at the interior and exterior to allow putty installation.
- 6 Continuous putty "rings" around each line to make them airtight when ganged together, and line set tape continued over the putty rings to compress them in place.
- 7 Continuous hard backer-rod around the line set in the duct collars and continuous sealant beads tooled around the line set.
- 8 Line set cover flashing fastened on shims with sealant tooled at the top and sides and over the fasteners.

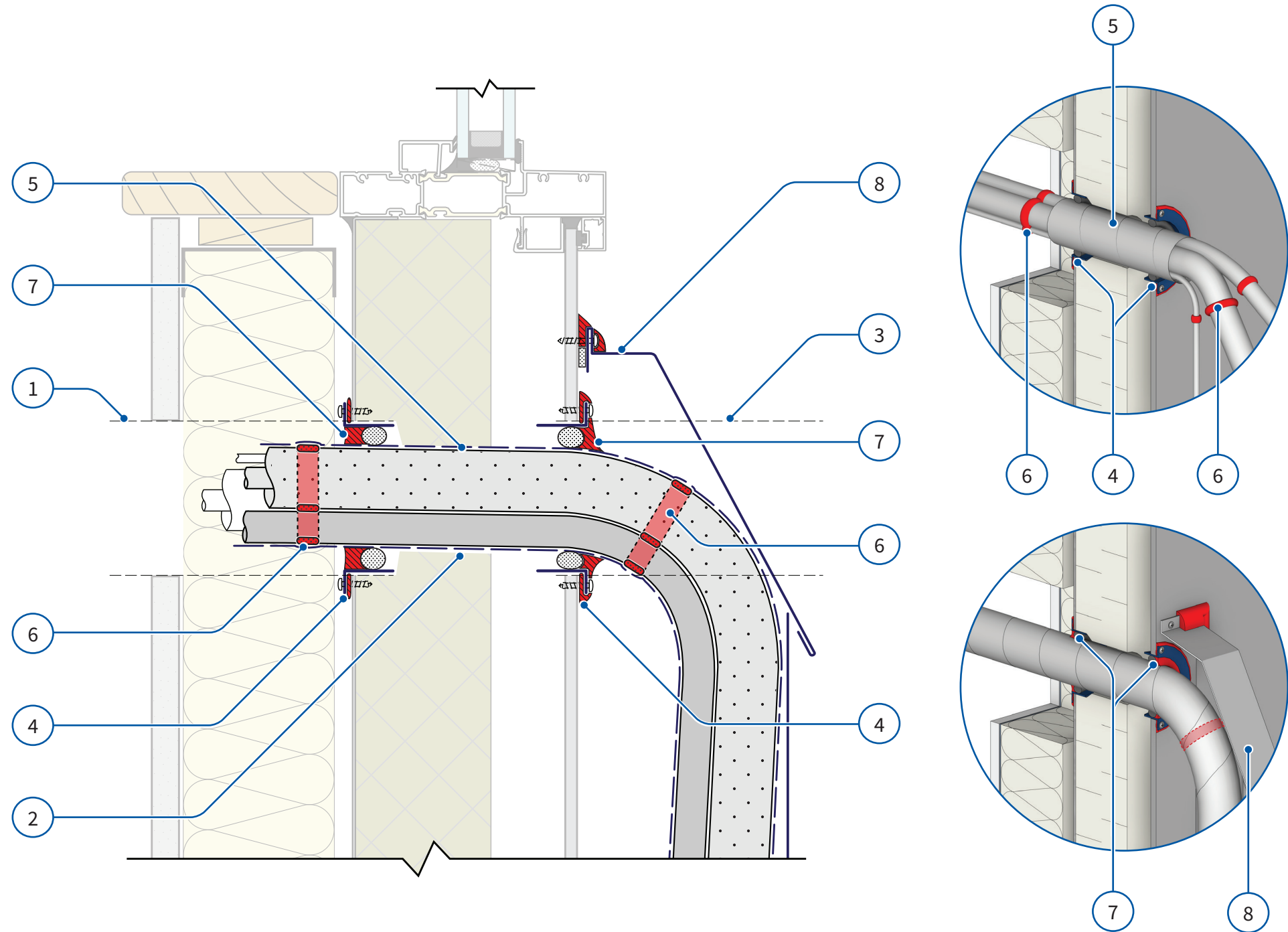

D-1F | Line Set Through Exterior-Insulated or Deep Rainscreen

Materials (for typical line set sizes)

- › 3" PVC conduit (schedule 20), 3" flanged duct collars
- › Construction sealant for low surface energy materials, hard backer-rod
- › Adhesive line set tape, putty sealant, line set flashing/cover kit

Steps (refer to Detailing Considerations on page 2)

- 1 3.25" hole saw opening in the interior finish and poly sheet, with a pilot hole to the exterior with a 2% downward slope.
- 2 5" hole saw opening in the cladding and exterior insulation, aligned with the pilot hole, made to avoid damage to sheathing membrane where possible.
- 3 3.25" hole saw opening in the sheathing membrane and sheathing (after the 5" hole in the cladding and insulation).
- 4 Sealant tooled between the interior poly sheet and the interior finish around the perimeter of the hole.
- 5 3" PVC conduit cut to depth and inserted through the openings.
- 6 3" interior duct collar set into sealant around the PVC conduit and interior finish, and fastened in place as needed.
- 7 Circular EPDM membrane with an under-sized hole fit around the conduit and carefully set into a continuous bead of sealant on the sheathing membrane around the hole (see sizing guide at top right).
- 8 Line set inserted through the PVC conduit, with continuous line set tape over the portions within the conduit, and exposed lines splayed to allow putty installation.
- 9 Hard backer rod baffle/insulation around the line set in the conduit as space and access permits.
- 10 Continuous putty "rings" around each line to make them airtight when ganged together, and line set tape continued over the putty rings to compress them in place.
- 11 Continuous hard backer-rod and sealant bead tooled around the line set in the conduit.
- 12 Semi-rigid mineral wool insulation fitted around the line set, pinned in place as needed.
- 13 Line set cover receiver set into sealant on the cladding and fastened in place.
- 14 Line set cover clipped/fastened in place as needed.

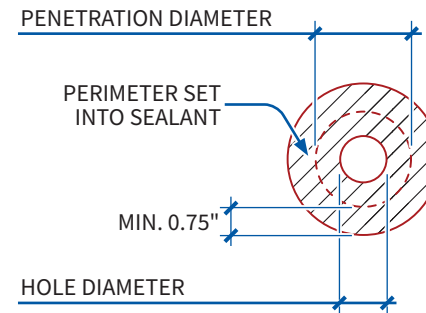

Typical EPDM gasket hole diameter sizing guide

- › Penetrations $\leq 1"$ – size hole diameter @ approximately 40% of the penetration diameter
- › Penetrations $>1"$ to $\leq 3.5"$ – size hole diameter @ approximately 60% of the penetration diameter
- › Penetrations $> 3.5"$ – size hole diameter @ 1.5" smaller than the penetration diameter

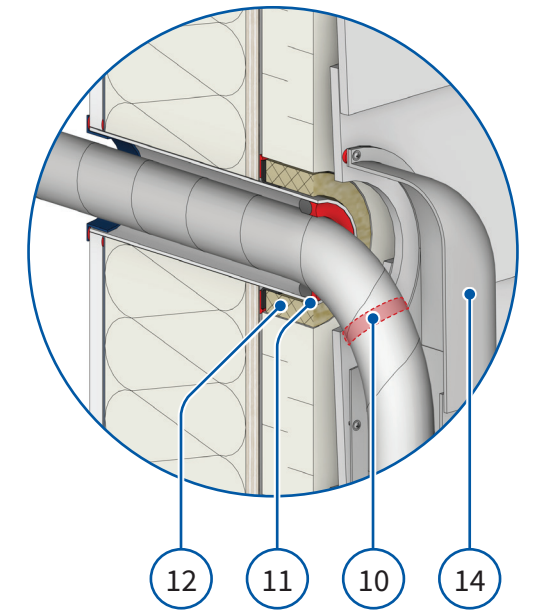
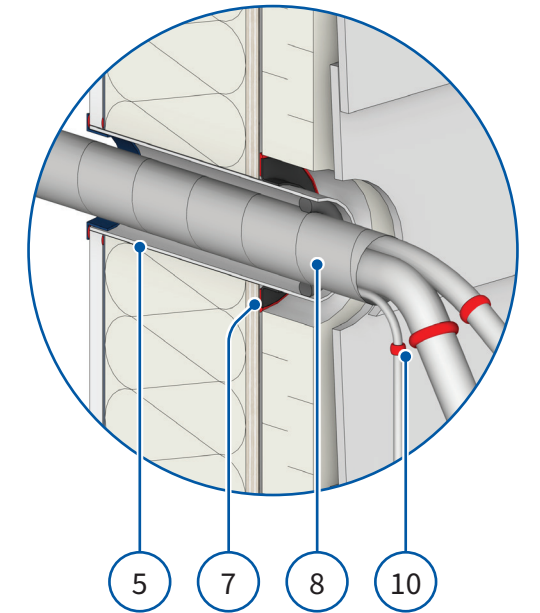
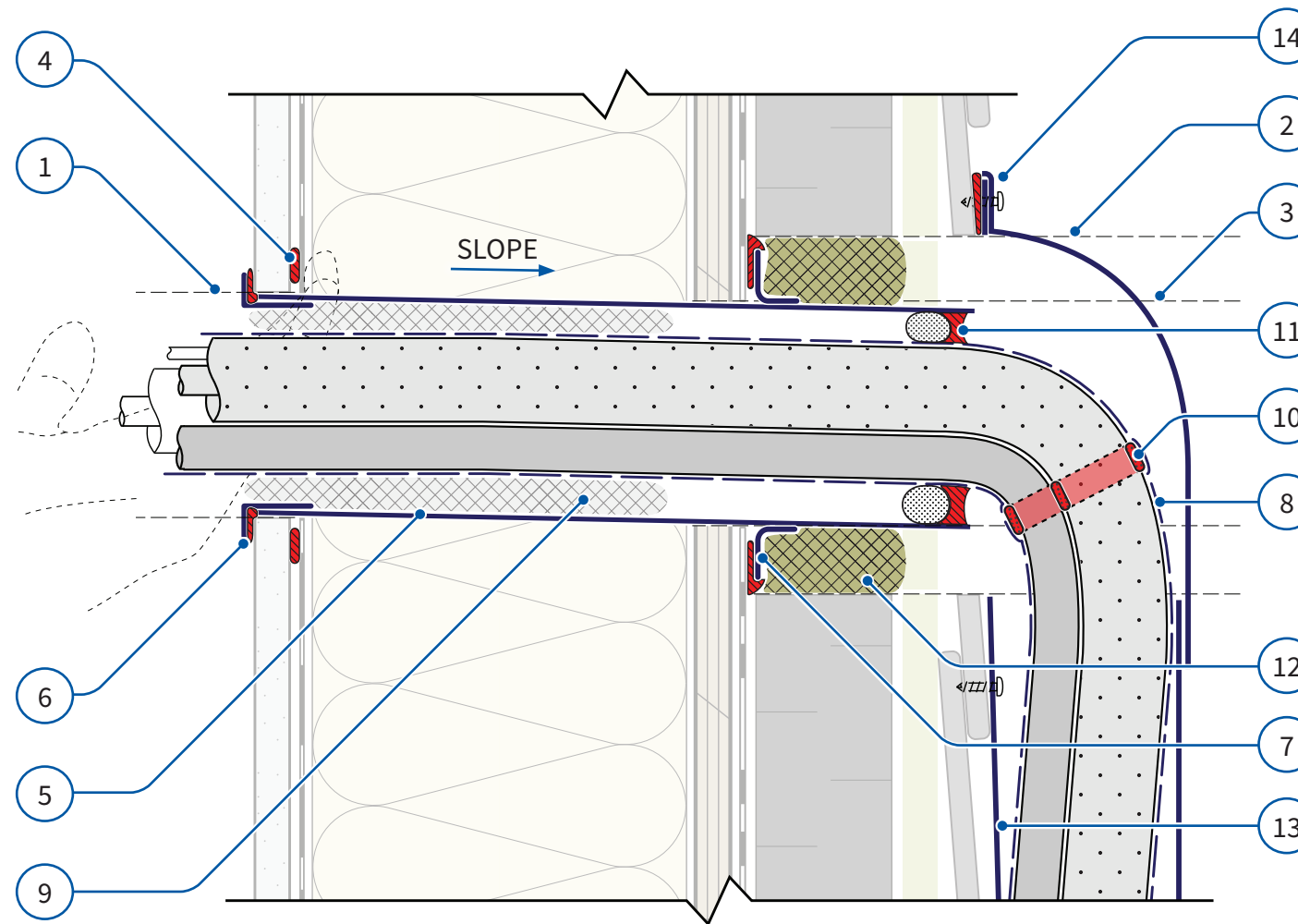

D-1G | Line Set Through Rainscreen in High Exposure and/or Firestopping Conditions

Materials (for typical line set sizes)

- › 3" PVC conduit (schedule 20), firestopping accessories
- › Construction sealant for low surface energy materials, hard backer-rod
- › High-performance detailing tape, unreinforced 60 mil EPDM gasket membrane
- › Adhesive line set tape, putty sealant, trim board, flashing, and line set cover kit

Steps (refer to Detailing Considerations on page 2)

- 3.25" hole saw opening in the interior finish and poly sheet, with a pilot hole to the exterior with a 2% downward slope.
- Rectangular opening in the cladding around the pilot hole, avoiding damage to the sheathing membrane.
- 3.25" hole saw opening in the sheathing membrane and sheathing.
- Sealant tooled between the interior poly sheet and the interior finish around the perimeter of the hole.
- Horizontal slit cut through the sheathing membrane to the width of the EPDM patch and located above the new hole saw opening to allow lapping and taping of the EPDM patch (see Step 6).
- 3" PVC conduit sized to fit inset from the interior finish (supported as needed) and aligned with the new trim board (see Step 13). EPDM membrane with an under-sized hole fit around the conduit at the exterior and with its top edge slipped behind the sheathing membrane through the slit from Step 5 (see sizing guide at top right).
- All edges of the EPDM patch taped onto the sheathing membrane with high-performance detailing tape.
- Line set inserted through the PVC conduit, with continuous line set tape over the portions within the conduit, and lines splayed to allow putty installation.
- Hard backer rod baffle/insulation around the line set in the conduit as space and access permits.
- Continuous putty "rings" around each line to make them airtight when ganged together, and line set tape continued over the putty rings to compress them in place.
- Continuous hard backer-rod and sealant bead tooled around the line set in the conduit.
- Interior firestopping sealant and collar detailing as required (see Firestopping on page 3).
- Flashing and trim board fastened in place on furring as needed. Sealant tooled at the sides of the trim board. Line set cover components set into sealant and clipped/fastened in place.

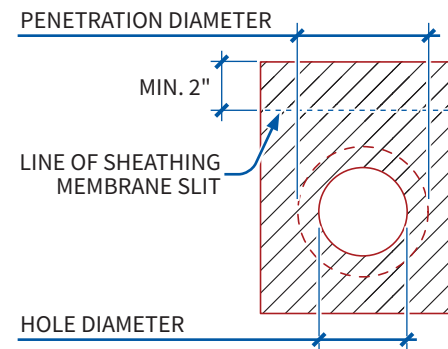

Typical EPDM gasket hole diameter sizing guide

- › Penetrations ≤ 1" – size hole diameter @ approximately 40% of the penetration diameter
- › Penetrations >1" to ≤ 3.5" – size hole diameter @ approximately 60% of the penetration diameter
- › Penetrations > 3.5" – size hole diameter @ 1.5" smaller than the penetration diameter

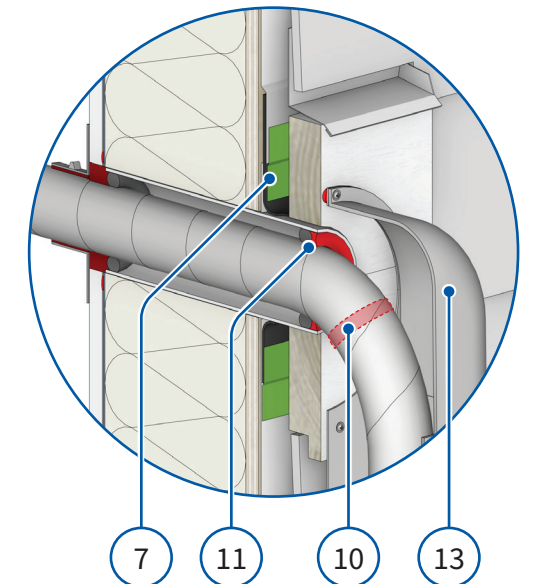
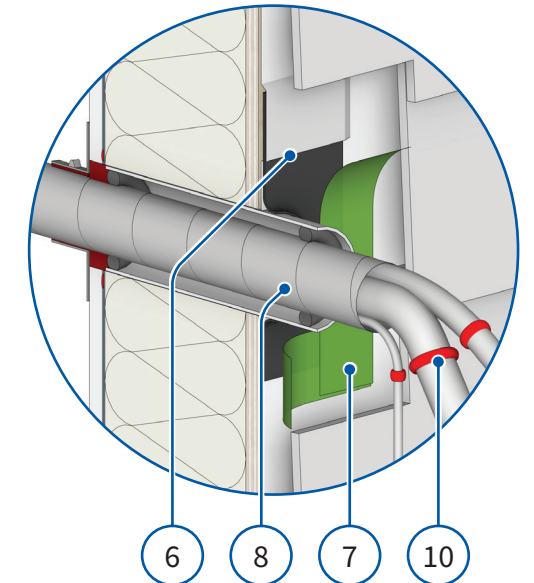
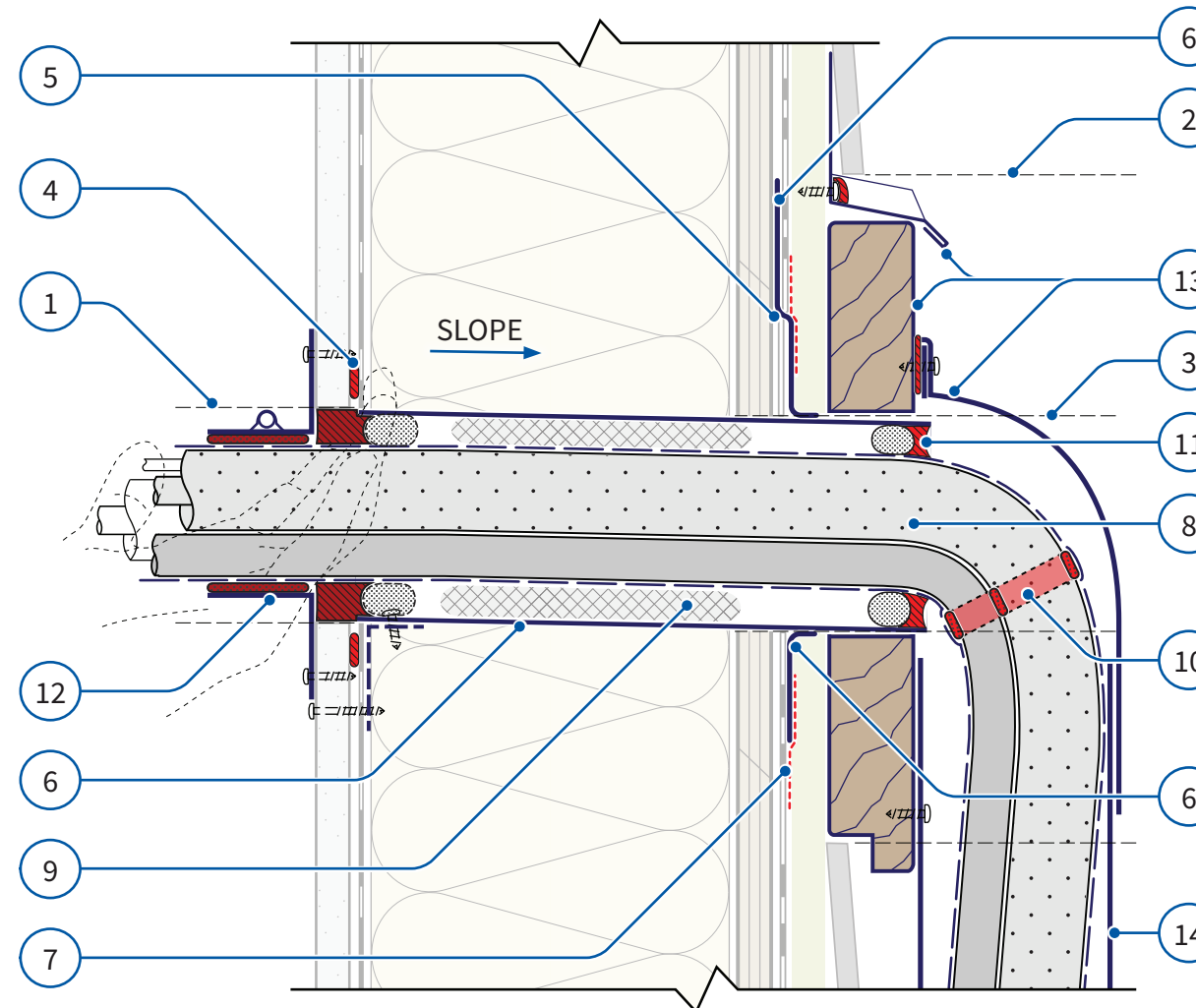

D-2A | Electrical Disconnect Box on Rainscreen Cladding

Materials

- › Electrical wiring, disconnect box, snap-in cable connector
- › Construction sealant for low surface energy materials
- › Putty sealant, firestopping accessories
- › Unreinforced 60 mil EPDM gasket membrane (optional)

Steps (refer to Detailing Considerations on page 2)

- 1 1.25" hole saw opening in the inner interior finish, held back to avoid damage to the interior poly. Hole saw bit pried back and forth to release the hole offcut.
- 2 Wire inserted through the hole saw pilot hole in the poly and restrained with fasteners or putty sealant as needed to centre the wire in the opening.
- 3 Sealant (firestopping if necessary) tooled around the wire, using the exposed poly as backer, to fully fill the opening in the interior finish.
- 4 For the exterior penetration, 1.5" hole saw opening in the cladding, avoiding damage to sheathing membrane where possible.
- 5 Hole matching the diameter of the electrical wire drilled through the sheathing membrane and sheathing (after the 1.5" hole in the cladding).
- 6 Wire inserted through the hole and restrained as needed, with its final position centred in the opening.
- 7 Sealant tooled around the wire and onto the sheathing membrane. See also the D-3 details for detailing options if the penetration is not covered by the disconnect box.
- 8 Optional wire penetration sealing approach using EPDM (see also D-1F): Circular EPDM membrane with an under-sized hole fit around the wire and carefully set into a continuous bead of sealant on the sheathing membrane around the wire hole.
- 9 Disconnect box with snap-in connector fitted over the wire and fastened in place, with the connector positioned in the 1.5" opening.
- 10 Putty sealant around the wire at the connector within the disconnect box to reduce water tracking back to the sheathing membrane.
- 11 Sealant tooled at the top and side of the disconnect box or flashing as needed.

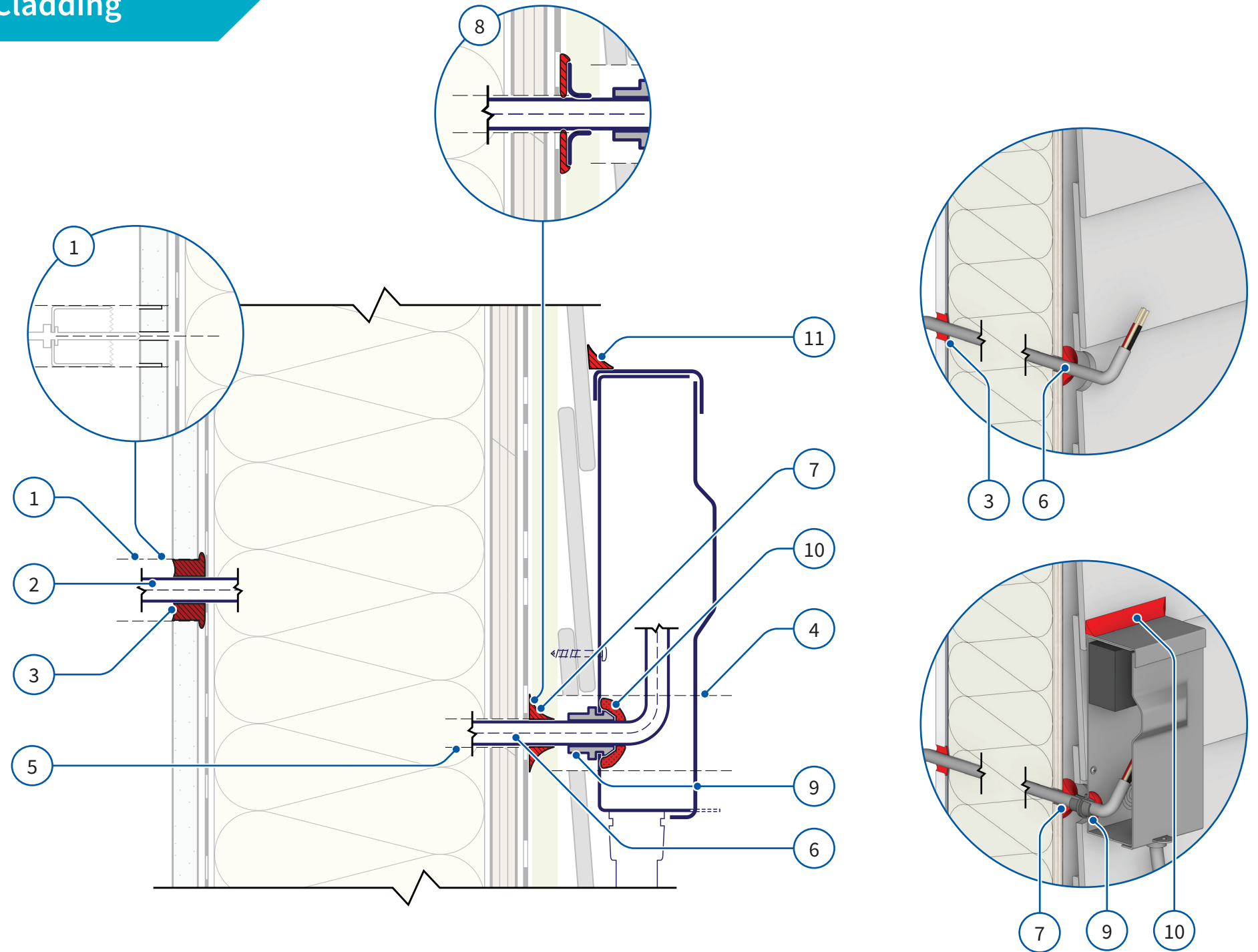

D-2B | Electrical Disconnect Box on Non-Rainscreen Cladding

Materials

- › Electrical wiring, disconnect box, snap-in cable connector
- › Construction sealant for low surface energy materials
- › Putty sealant, firestopping accessories

Steps (refer to Detailing Considerations on page 2)

- 1 1.25" hole saw opening in the inner interior finish, held back to avoid damage to the interior poly. Hole saw bit pried back and forth to release the hole offcut.
- 2 Wire inserted through the hole saw pilot hole in the poly and restrained with fasteners or putty sealant as needed to centre the wire in the opening.
- 3 Sealant (firestopping if necessary) tooled around the wire, using the exposed poly as backer, to fully fill the opening in the interior finish.
- 4 For the exterior penetration, 1.5" hole saw opening in the cladding and membrane, with a 0.125" kerf cut into the sheathing.
- 5 Hole matching the diameter of the wire drilled through the sheathing membrane and sheathing (after the 1.5" hole in the cladding).
- 6 Wire inserted through the hole and restrained as needed to centre it in the opening.
- 7 Sealant tooled around the wire onto the sheathing to fully fill the opening, including into the kerf and around the edge of the membrane and cladding where possible.
- 8 Disconnect box with snap-in connector fitted over the wire and fastened in place, with the connector centered in the 1.5" hole opening.
- 9 Putty sealant around the wire at the connector within the disconnect box.
- 10 Sealant at the top and sides of the disconnect box.

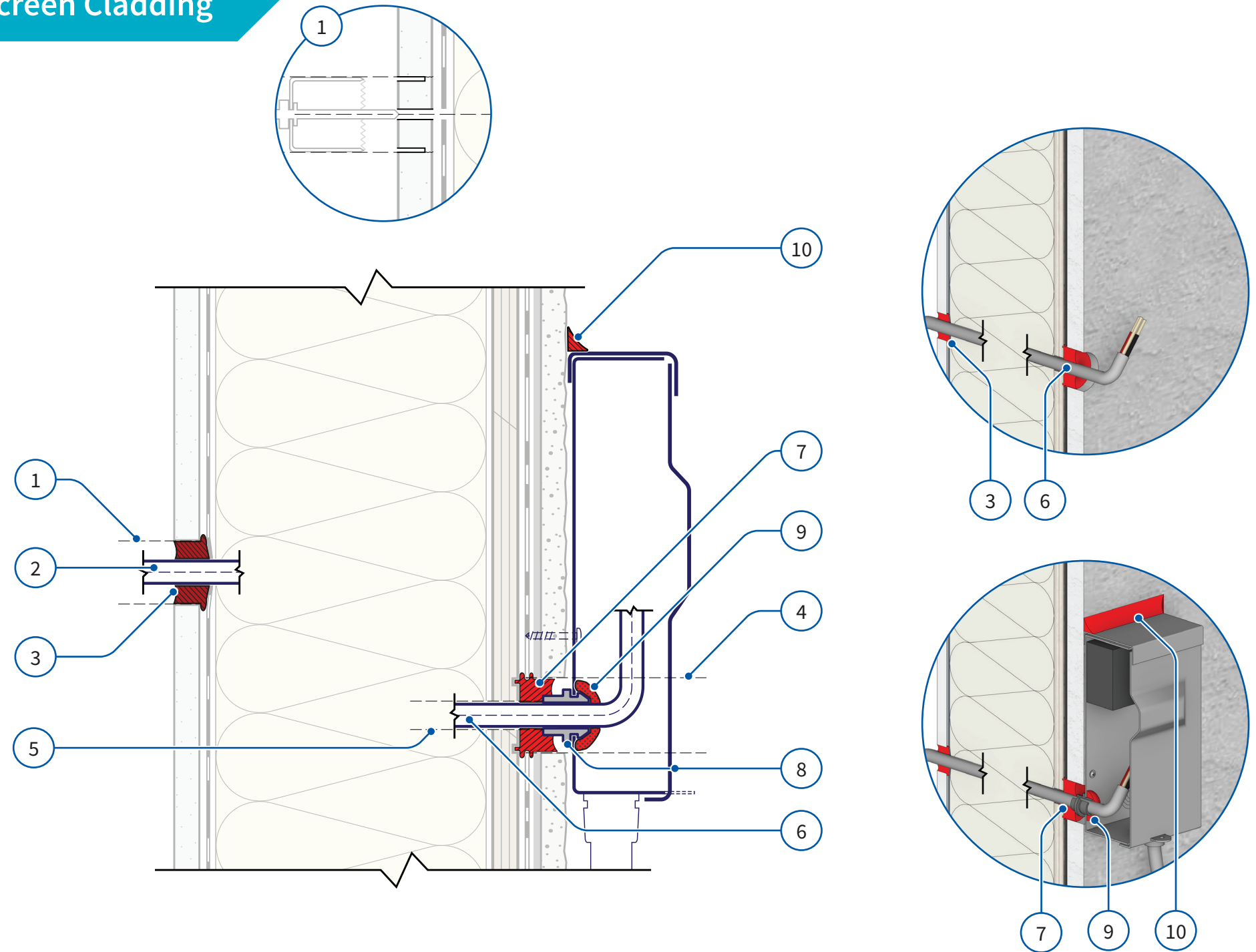

D-2C | Electrical Disconnect Box on Rainscreen Cladding in High Exposure Conditions

Materials

- › Electrical wiring, disconnect box, snap-in cable connector
- › Construction sealant for low surface energy materials
- › High-performance detailing tape, unreinforced 60 mil EPDM gasket membrane
- › Putty sealant, firestopping accessories, trim board, flashing

Steps (refer to Detailing Considerations on page 2)

- 1.25" hole saw opening in the inner interior finish, held back to avoid damage to the interior poly. Hole saw bit pried back and forth to release the hole offcut.
- Wire inserted through the hole saw pilot hole in the poly and restrained with fasteners or putty sealant as needed to centre the wire in the opening.
- Sealant (firestopping if necessary) tooled around the wire, using the exposed poly as backer, to fully fill the opening in the interior finish.
- Hole matching the diameter of the wire drilled through the cladding, sheathing membrane, and sheathing.
- Rectangular opening in the cladding with at least 3" clearance around the wire hole and tall enough to receive the backing trim board and flashing (see Step 9), avoiding damage to the sheathing membrane and removing furring strips as needed.
- Horizontal slit cut through the sheathing membrane to the width of the EDPM patch and located above the wire hole to allow lapping and taping of the EPDM patch (see Step 7).
- EPDM membrane with an under-sized hole fit over the electrical wire at the exterior and with its top edge slipped behind the sheathing membrane in the slit from Step 6 (see sizing guide at top right).
- All edges of the EPDM patch taped onto the sheathing membrane with high-performance detailing tape.
- Flashing and trim board fastened in place on furring as needed. Sealant tooled at the sides of the trim board.
- Disconnect box with snap-in connector fitted over the wire and fastened in place. Fire putty around the wire at the connector to reduce water tracking back along the wire.

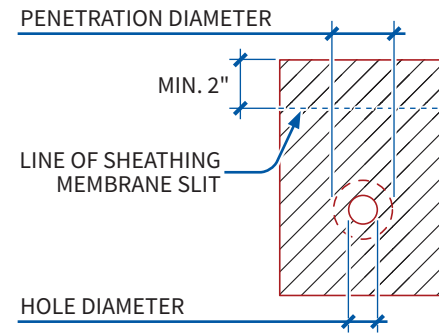

Typical EPDM gasket hole diameter sizing guide

- › Penetrations $\leq 1"$ – size hole diameter @ approximately 40% of the penetration diameter
- › Penetrations $>1"$ to $\leq 3.5"$ – size hole diameter @ approximately 60% of the penetration diameter
- › Penetrations $> 3.5"$ – size hole diameter @ 1.5" smaller than the penetration diameter

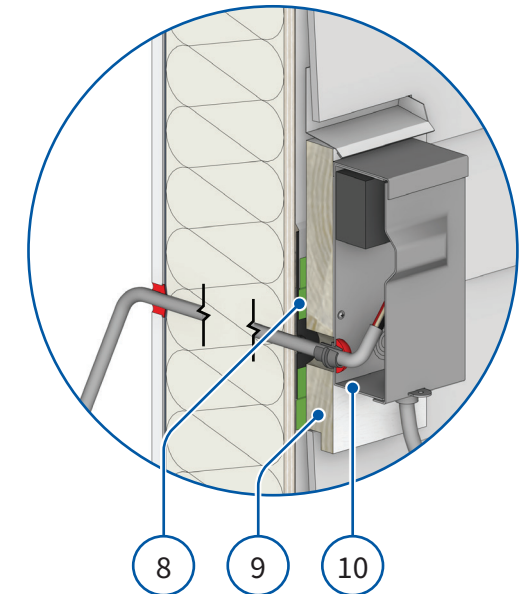
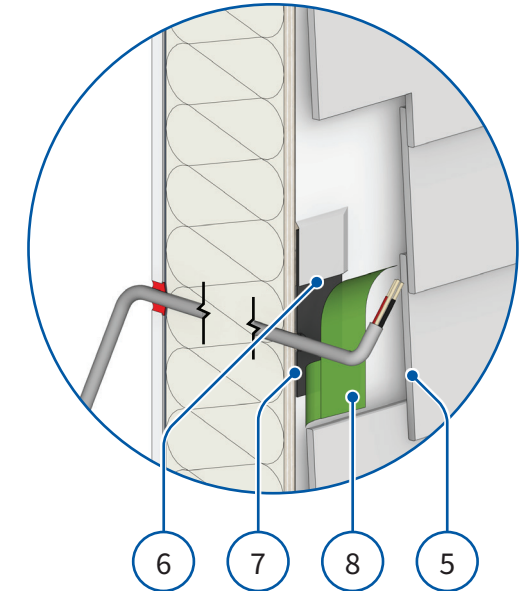
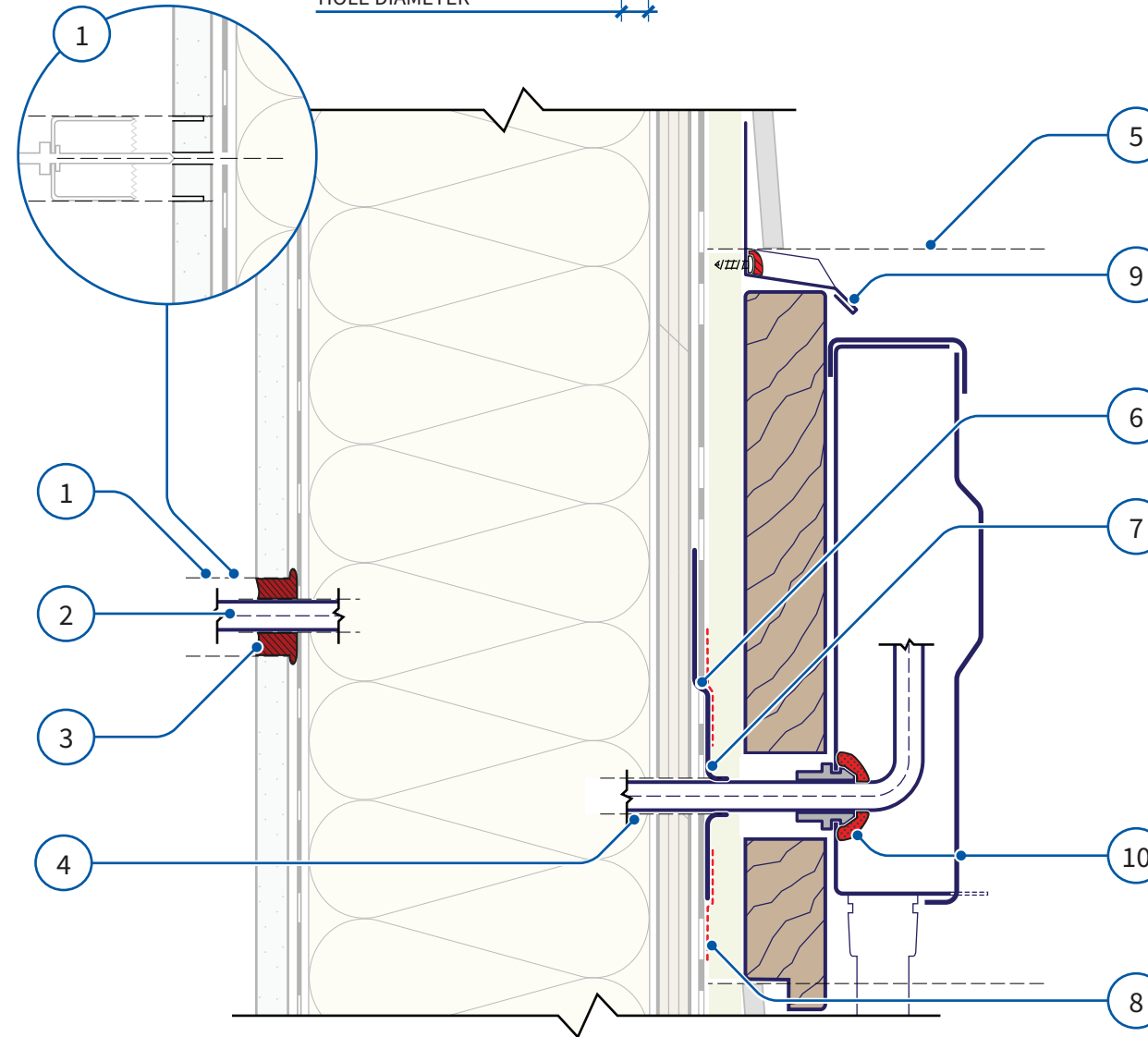

D-3A | Conduit/Pipe Through Rainscreen Cladding

Materials (for 1" Conduit/Pipe)

- › Construction sealant for low surface energy materials
- › Putty sealant, firestopping accessories
- › Interior cover plate, exterior cover flashing
- › Optional: unreinforced 60 mil EPDM gasket membrane

Steps (refer to Detailing Considerations on page 2)

- 1 2" hole saw opening in the inner interior finish, held back to avoid damage to the interior poly. Hole saw bit pried back and forth to release the hole offcut. Pilot hole to the exterior with a 2% downward slope.
- 2 For the exterior penetration, 2.5" hole saw opening in the cladding, avoiding damage to sheathing membrane where possible.
- 3 Hole matching the diameter of the conduit/pipe drilled through the sheathing membrane and sheathing (after the 2.5" hole in the cladding).
- 4 Conduit/pipe inserted through the holes and restrained with fasteners or putty sealant as needed, with its final position centred in the openings.
- 5 Sealant (firestopping if necessary) tooled around the interior of the conduit/pipe, using the exposed poly as backer to fully fill the opening in the interior finish. Interior cover plate installed around the conduit/pipe as needed.
- 6 Sealant around the conduit/pipe at the exterior sheathing membrane.
- 7 Optional conduit/pipe penetration sealing approach using EPDM: Circular EPDM membrane with an under-sized hole fit around the conduit/pipe and carefully set into a continuous bead of sealant on the sheathing membrane around the hole.
- 8 Exterior cover flashing around the conduit/pipe, slipped behind lap siding where possible and set into sealant at the top and sides (see also D-3B).
- 9 Sealant tooled around the conduit/pipe at the exterior cover flashing.
- 10 Putty sealant within the conduit around wires where present.

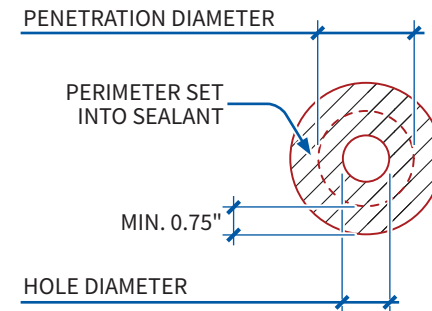
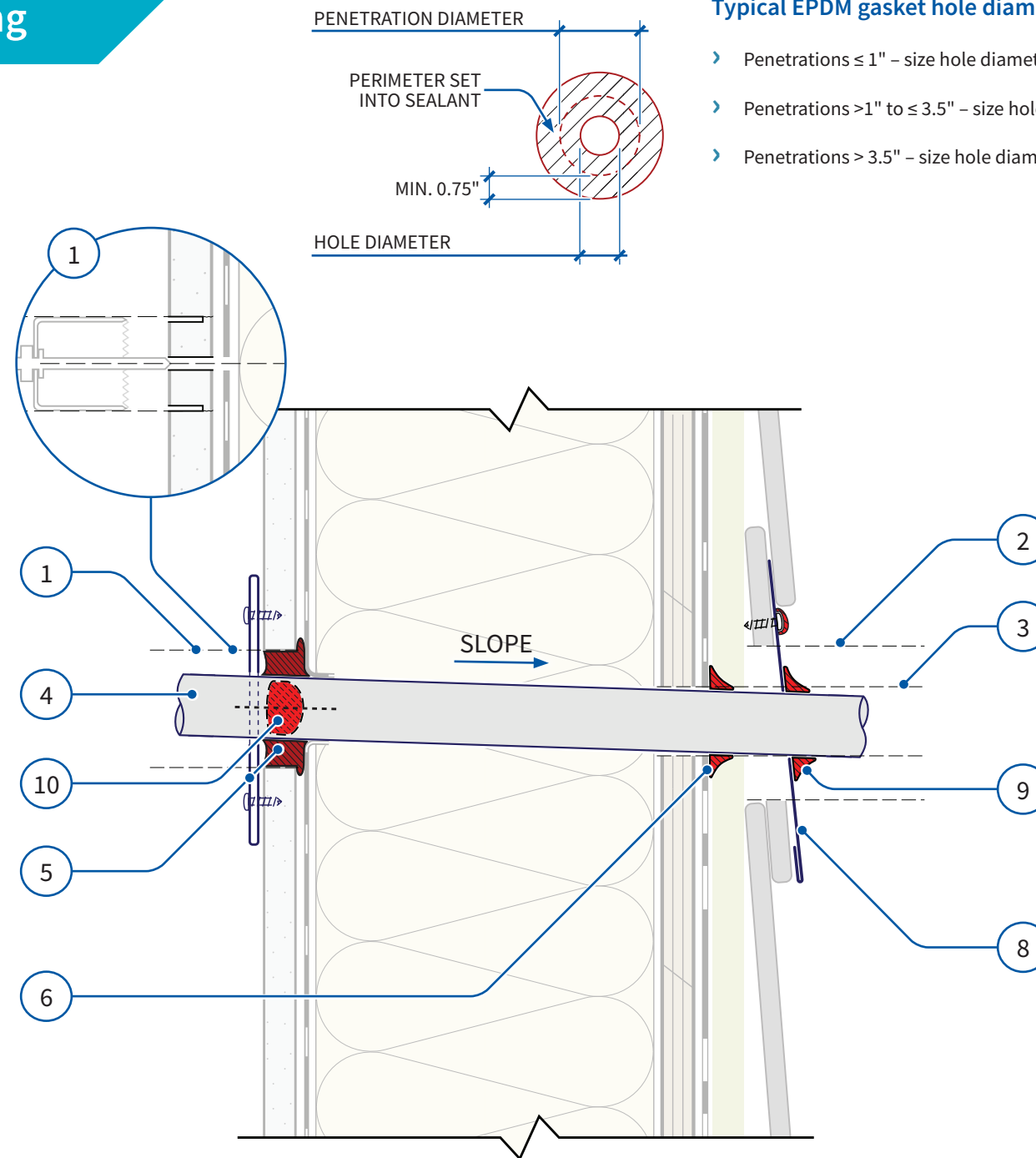

Typical EPDM gasket hole diameter sizing guide

- › Penetrations $\leq 1"$ – size hole diameter @ approximately 40% of the penetration diameter
- › Penetrations $>1"$ to $\leq 3.5"$ – size hole diameter @ approximately 60% of the penetration diameter
- › Penetrations $> 3.5"$ – size hole diameter @ 1.5" smaller than the penetration diameter

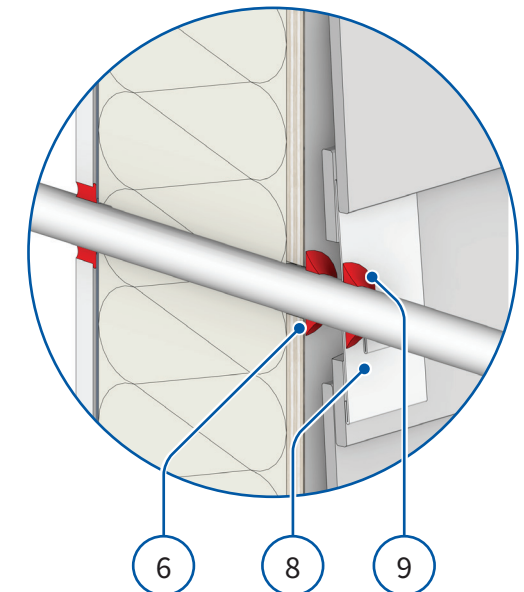
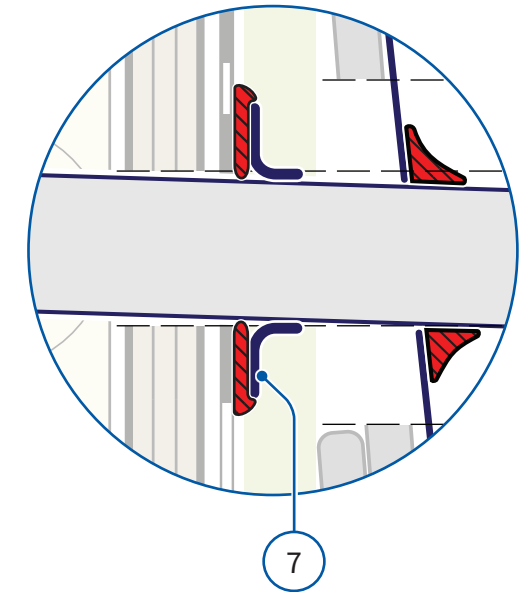

D-3B | Conduit/Pipe Through Non-Rainscreen Cladding

Materials (for 1" Conduit/Pipe)

- › Construction sealant for low surface energy materials
- › Putty sealant, firestopping accessories
- › Interior cover plate, exterior cover flashing

Steps (refer to Detailing Considerations on page 2)

- 1 2" hole saw opening in the inner interior finish, held back to avoid damage to the interior poly. Hole saw bit pried back and forth to release the hole offcut. Pilot hole to the exterior with a 2% downward slope.
- 2 For the exterior penetration, 2" hole saw opening in the cladding and membrane, with a 0.125" kerf cut into the sheathing.
- 3 Hole matching the diameter of the conduit/pipe drilled through the sheathing membrane and sheathing (after the 2" hole in the cladding).
- 4 Conduit/pipe inserted through the holes and restrained with fasteners or putty sealant as needed, with its final position centred in the openings.
- 5 Sealant (firestopping if necessary) tooled around the interior of the conduit/pipe, using the exposed poly as backer to fully fill the opening in the interior finish. Interior cover plate installed around the conduit/pipe as needed.
- 6 Sealant tooled around the wire onto the sheathing to fully fill the opening, including into the kerf and around the edge of the membrane and cladding where possible.
- 7 Exterior cover flashing around the conduit/pipe, set into sealant at the top and sides, and with a reglet profile and sealant tooled at the top edge.
- 8 Sealant tooled around the conduit/pipe at the exterior cover flashing.
- 9 Putty sealant within the conduit around wires where present.

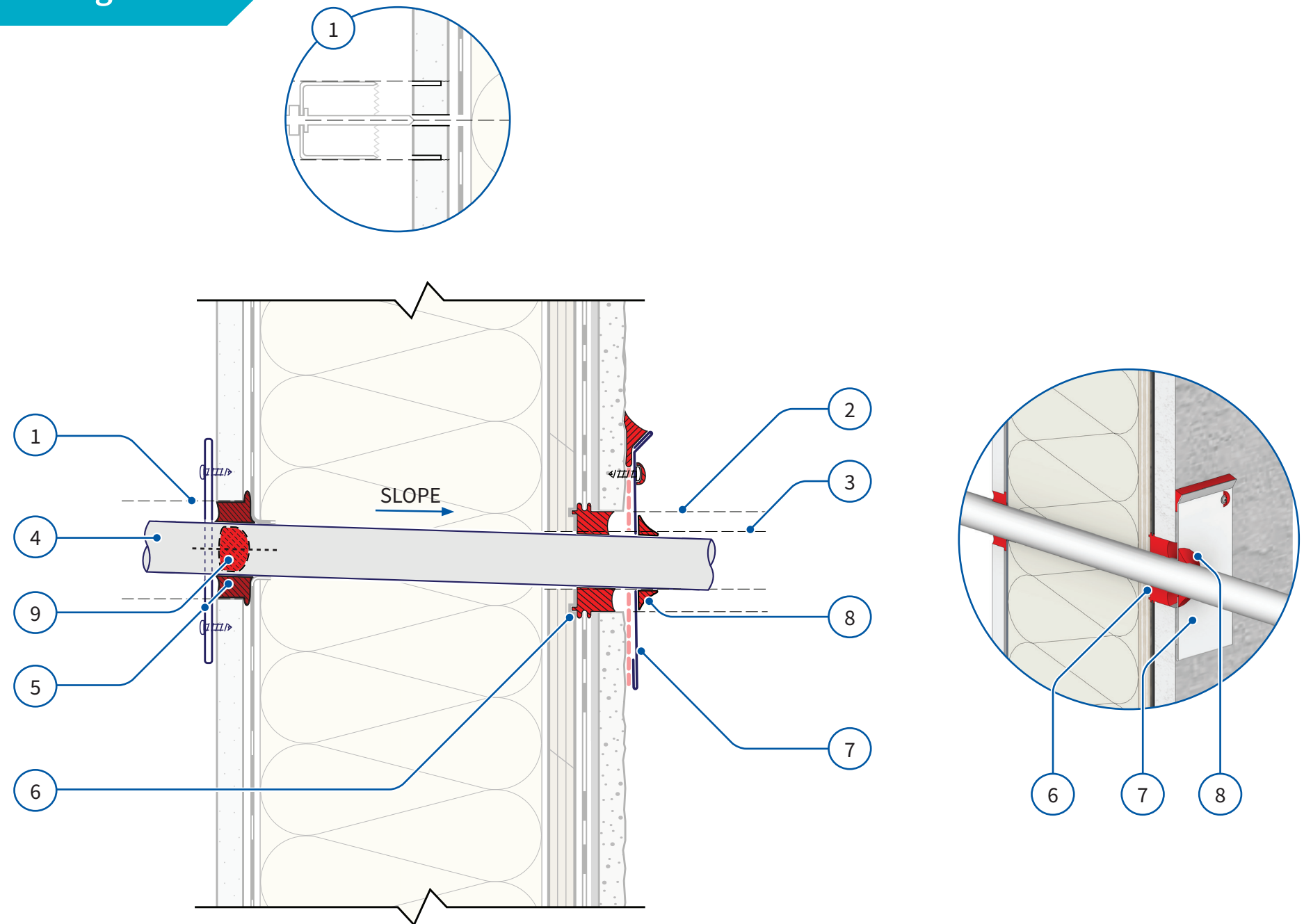

D-3C | Conduit/Pipe Through Rainscreen Cladding in High Exposure Conditions

Materials

- › Electrical wiring, disconnect box, snap-in cable connector
- › Construction sealant for low surface energy materials
- › High-performance detailing tape, unreinforced 60 mil EPDM gasket membrane
- › Putty sealant, firestopping accessories, trim board, flashing

Steps (refer to Detailing Considerations on page 2)

- 1 2" hole saw opening in the inner interior finish, held back to avoid damage to the interior poly. Hole saw bit pried back and forth to release the hole offcut. Pilot hole to the exterior with a 2% downward slope.
- 2 Hole matching the diameter of the conduit/pipe drilled through the cladding, sheathing membrane, and sheathing.
- 3 Rectangular opening in the cladding with at least 3" clearance around the hole and large enough to receive the backing trim board and flashing (see Step 7), avoiding damage to the sheathing membrane and removing furring strips as needed.
- 4 Horizontal slit cut through the sheathing membrane to the width of the EPDM patch and located above the hole to allow lapping and taping of the EPDM patch (see Step 5).
- 5 EPDM membrane with an under-sized hole fit over the conduit/pipe at the exterior and with its top edge slipped behind the sheathing membrane in the slit from Step 4 (see sizing guide at top right).
- 6 Conduit/pipe inserted through the holes and restrained with fasteners or putty sealant as needed, with its final position centred in the openings.
- 7 Sealant (firestopping if necessary) tooled around the interior of the conduit/pipe, using the exposed poly as backer to fully fill the opening in the interior finish. Interior cover plate installed around the conduit/pipe as needed.
- 8 All edges of the EPDM patch taped onto the sheathing membrane with high-performance detailing tape.
- 9 Flashing and trim board fastened in place on furring as needed. Sealant at the sides of the trim board.
- 10 Putty sealant within the conduit around wires where present.

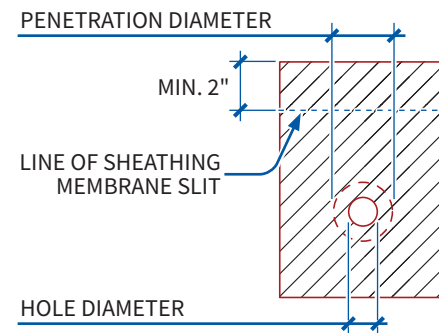

Typical EPDM gasket hole diameter sizing guide

- › Penetrations $\leq 1"$ – size hole diameter @ approximately 40% of the penetration diameter
- › Penetrations $>1"$ to $\leq 3.5"$ – size hole diameter @ approximately 60% of the penetration diameter
- › Penetrations $> 3.5"$ – size hole diameter @ 1.5" smaller than the penetration diameter

